



QUICK SELECTION / Selezione veloce

input speed (n_1) = 1400 min⁻¹

Output Speed n_2 [min ⁻¹]	Ratio i	Motor power P_{1M} [kW]	Output torque M_{2M} [Nm]	Service factor f.s.	Nominal power P_{1R} [kW]	Nominal torque M_{2R} [Nm]	Available B5 motor flanges			B14 motor flanges not available				Dynamic efficiency RD	Tooth Module [mm]	Ratios code
							E	F	G	-	-	-	-			
							90	100 112	132	-	-	-	-			
187	7.5	7.5	345	2.1	16.1	741		B					90	6.11	01	
140	10	7.5	455	1.8	13.5	820		B					89	6.45	02	
93	15	7.5	668	1.4	10.3	917		B					87	6.72	03	
70	20	7.5	870	1.0	7.8	905		B					85	5.24	04	
56	25	5.5	788	1.2	6.5	931		B					84	4.28	05	
46.7	30	5.5	900	1.2	6.4	1047		B					80	6.91	06	
35	40	4.0	851	1.2	4.9	1043		B					78	5.36	07	
28	50	4.0	1023	0.9	3.8	972	B						75	4.35	08	
23.3	60	3.0	896	1.0	3.1	928	B						73	3.65	09	
17.5	80	2.2	816	1.0	2.3	853	B						68	2.76	10	
14	100	1.5	655	1.1	1.7	742	B						64	2.23	11	

Motor Flanges Available
Flange Motore Disponibili

B) Supplied with Reduction Bushing
Fornito con Bussola di Riduzione

B) Available on Request without reduction bushing
Disponibile a Richiesta senza Bussola di Riduzione

C) Motor Flange Holes Position
Posizione Fori Flangia Motore

EN Unit Q13 is supplied without lubricant and equipped with a breather, level and drain plugs. User can add mineral oil keeping existing plugs. Should the user wish to fill it with synthetic oil, it is recommended to replace the existing plugs with a closed plug. See table 1 for lubrication and recommended quantity. In table 2 please see possible radial loads and axial loads on the gearbox.

I Il riduttore tipo Q13 è fornito privo di lubrificazione con tappi di sfiato, livello e scarico olio. L'utente può immettere olio minerale mantenendo i tappi esistenti. Se immetterà olio sintetico, dovrà sostituire i tappi esistenti con altri tipo chiuso. Tab.1 per oli e quantità consigliati. Tab.2 carichi radiali e assiali applicabili al riduttore.

D Das Getriebe der Baugröße Q13 wird ohne Schmiermittel geliefert. Es ist jedoch mit Einfüllschraube, Überdruckventil und Ablassschraube ausgerüstet. Das benötigte mineralische Öl kann über die Einfüllschraube eingefüllt werden. Sollte synthetisches Öl bevorzugt werden, so ist sind das eingebaute Überdruckventil durch eine geschlossenen Schraube zu ersetzen. In Tabelle 1 ist die Schmiermenge und das empfohlene Schmiermittel angegeben. In Tabelle 2 sind die zulässigen Radial - und Axialbelastungen des Getriebes aufgeführt.

F Le réducteur de type Q13 est fourni sans lubrification et avec un bouchon de remplissage, de niveau et d'évacuation de l'huile. L'utilisateur peut y verser de l'huile minérale en conservant les bouchons existants. S'il y versera de l'huile synthétique, il devra substituer les bouchons existants avec d'autres bouchons de type fermé. Voir tableau 1 concernant les huiles et les quantités conseillées. Voir tableau 2 concernant les charges radiales et axiales applicables au réducteur.

E El reductor tamaño Q13 se suministra sin lubricante, provisto de tapones de respiración, nivel y descarga de aceite. El usuario puede utilizar aceite mineral, manteniendo los tapones existentes. Si prefiere utilizar aceite sintético deberá sustituir los tapones existentes por tapones ciegos. La prerreducción se suministra con tapones ciegos, lubricado de por vida con aceite sintético. Ver tabla 1, para cantidades y aceites recomendados. En la tabla 2, se encuentran las cargas radiales y axiales admitidas por el reductor.

B3	B6	B7	B8	V5	V6
4.50 LT	3.50 LT	3.50 LT	3.30LT	4.50 LT	3.30LT

AGIP Blasias 460

For all details on lubrication and plugs check our website [tab. 1](#)
Per maggiori dettagli su lubrificazione e tappi olio vedi il nostro sito web

RADIAL AND AXIAL LOADS

Output shaft
Albero di uscita

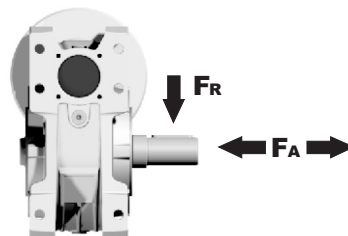

n_2 [min ⁻¹]	FA [N]	FR [N]
200	960	4800
150	1100	5500
100	1240	6200
75	1380	6900
50	1560	7800
25	2000	10000
15	2400	12000

Input shaft
albero in entrata

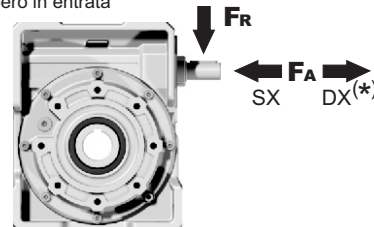

n_1 [min ⁻¹]	FA [N]	FR [N]
1400	300	1500

*Strong axial loads in the DX direction are not allowed.
Non sono consentiti forti carichi assiali con direzione DX

tab. 2

PQ13**FB**... Basic wormbox
Riduttore base

Gearbox weight
peso riduttore **48.0 kg**

M. flanges	Kit code	øF	A
90B5	KQ13.4.041	200	180
100/112B5	KQ13.4.042	250	180
132B5	KQ13.4.043	300	180

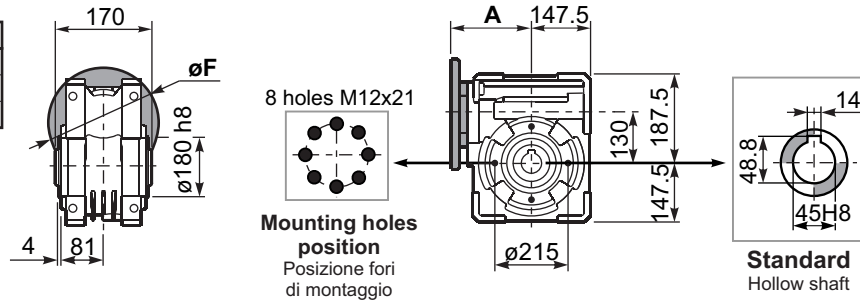

PQ13**FC**... Square flange
Flangia quadrata

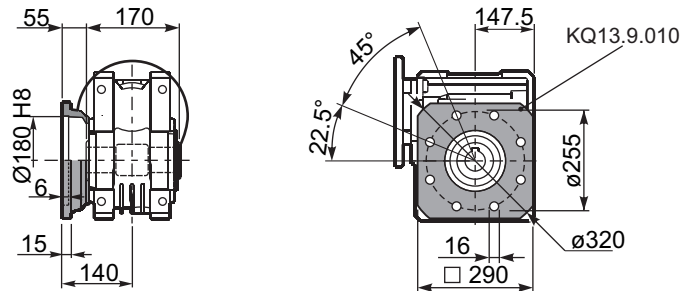

PQ13**FB**... Feet
Piedini

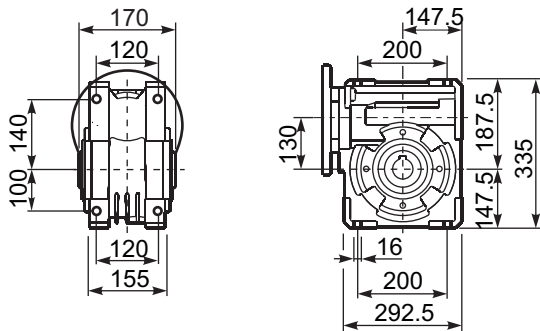

PQ13**BR**... Reaction arm
Braccio di reazione

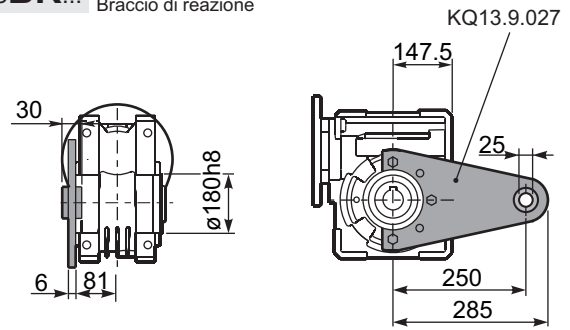

PQ13.....**S**... Single Shaft
Albero lento semplice

PQ13.....**D**... Double Shaft
Albero lento bisp.

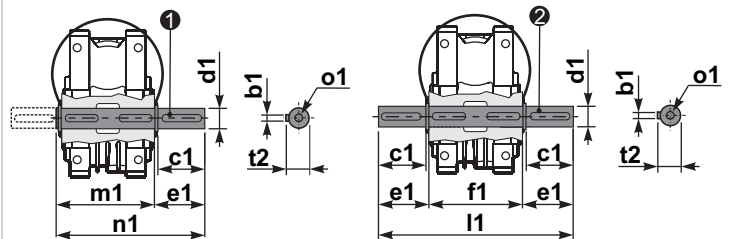

① kit cod. KQ13.5.028 type B

② kit cod. KQ13.5.029 type B

	b1	c1	d1	e1	f1	l1	m1	n1	t2	o1
type	14	80	45 ^{-0.005} _{-0.020}	85	170	340	180	265	48.5	M16
type	-	-	-	-	-	-	-	-	-	-