

## QUICK SELECTION / Selezione veloce

input speed ( $n_1$ ) = 1400 min<sup>-1</sup>

Output Speed $n_2$ [min <sup>-1</sup> ]	Ratio $i$	Motor power $P_{1M}$ [kW]	Output torque $M_{2M}$ [Nm]	Service factor f.s.	Nominal power $P_{1R}$ [kW]	Nominal torque $M_{2R}$ [Nm]	Available B5 motor flanges					Available B14 motor flanges				Output Shaft 	Ratios code	
							-C	-D	-E	-F	-G	-R	-T	-U	-V			
							71	80	90	100 112	132	80	90	100 112	132			
213	<b>6.57</b>	7.5	312	1.2	8.8	380	B										3018	01
185	<b>7.56</b>	7.5	358	1.1	7.9	390	B										3016	02
159	<b>8.82</b>	7.5	419	1.0	7.1	410	B										3014	03
113	<b>12.39</b>	7.5	588	1.0	7.2	580	B										2018	04
98	<b>14.24</b>	5.5	499	1.2	6.4	600	B										2016	05
84	<b>16.75</b>	5.5	587	1.1	6.1	665	B										1618	06
73	<b>19.25</b>	5.5	675	1.0	5.4	675	B										1616	07
64	<b>21.78</b>	4	558	1.2	4.7	675	B										1318	08
56	<b>25.04</b>	4	642	1.1	4.1	675	B										1316	09
47.9	<b>29.23</b>	4	750	0.9	3.5	675	B										1314	10
45.7	<b>30.65</b>	3	592	1.1	3.4	675	B										1116	11
39.1	<b>35.78</b>	3	691	1.0	2.9	675	B										1114	12
36.3	<b>38.55</b>	2.2	548	1.1	2.3	580	B										818	13
31.6	<b>44.32</b>	2.2	630	1.1	2.3	665	B										816	14
27.1	<b>51.74</b>	2.2	735	0.9	2.0	675	B										814	15
22.9	<b>61.03</b>	1.1	437	1.1	1.2	480	B										616	16
19.6	<b>71.25</b>	1.1	510	1.1	1.2	560	B										614	17

The dynamic efficiency is **0.96** for all ratios

**Motor Flanges Available**  
Flange Motore Disponibili

**B) Supplied with Reduction Bushing**  
Fornito con Bussola di Riduzione

**B) Available on Request without reduction bushing**  
Disponibile a Richiesta senza Bussola di Riduzione

**C) Motor Flange Holes Position**  
Posizione Fori Flangia Motore

**EN** Unit **H62C** is supplied with synthetic oil for lifetime lubrication, no maintenance is necessary. See table 1 for lubrication and recommended quantity. In table 2 please see possible radial loads and axial loads on the gearbox.

**I** Il riduttore **H62C** viene fornito completo di olio sintetico per la lubrificazione permanente e non necessita di alcuna manutenzione. Vedi tab.1 per oli e quantità consigliati. In tab.2 sono presenti i carichi radiali e assiali applicabili al riduttore.

**D** Das Getriebe **H62C** ist mit synthetischem Öl gefüllt und ist lebensdauergeschmiert. In Tabelle 1 ist die Schmiermenge und das empfohlene Schmiermittel angegeben. In Tabelle 2 sind die zulässigen Radial - und Axialbelastungen des Getriebes aufgeführt.

**F** Le réducteur **H62C** est fourni complet avec de l'huile synthétique pour la lubrification permanente et ne nécessite aucun entretien. Voir tableau 1 concernant les huiles et les quantités conseillées. Les charges radiales et axiales applicables au réducteur sont précisées dans le tableau 2.

**E** El reductor tamaño **H62C** se suministra, lubricado de por vida con aceite sintético y no requieren mantenimiento alguna. Ver tabla 1, para cantidades y aceites recomendados. En la tabla 2, se encuentran las cargas radiales y axiales admitidas por el reductor.

Standard supplied	For these mounting position specify in the order or add oil					
	Per queste posizioni specificare in fase d'ordine o aggiungere olio					
B3	B6	B7	B8	V5	V6	V8
2.25 LT	3.20 LT	3.00 LT	2.25 LT	4.35 LT	2.35 LT	Ask
AGIP Telium VSF 320			SHELL Omala S4 WE 320			

For all details on lubrication and plugs check our website **tab. 1**  
Per maggiori dettagli su lubrificazione e tappi olio vedi il nostro sito web

### RADIAL AND AXIAL LOADS

**Output shaft**  
Albero di uscita

$F_{eq} = FR \cdot \frac{149.5}{X+119.5}$

$n_2$	FA	FR	$n_2$	FA	FR	$n_2$	FA	FR
300	600	3000	140	720	3600	70	940	4700
250	640	3200	120	740	3700	40	1220	6100
200	690	3460	85	860	4300	15	1300	6500

**On request reinforced bearings to increase loads.**  
A richiesta cuscinetti rinforzati per aumentare i carichi.

**Input shaft**  
Albero in entrata

$n_1$	FA	FR
1400	450	2250
900	500	2500
500	600	3000

tab. 2

**PH62C...**

Basic gearbox  
Riduttore base

M. flanges	Kit code	øF	A
71B5	K023.4.041	160	227
80/90B5	K023.4.042	200	229
100/112B5	K023.4.043	250	238
132B5	KC50.4.043	300	256
80B14	K085.4.046	120	229
90B14	K085.4.045	140	229
100/112B14	K085.4.047	160	238
132B14	KC50.4.041	200	256

**Standard**  
Hollow shaft

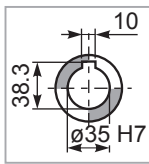

**On request**  
A richiesta

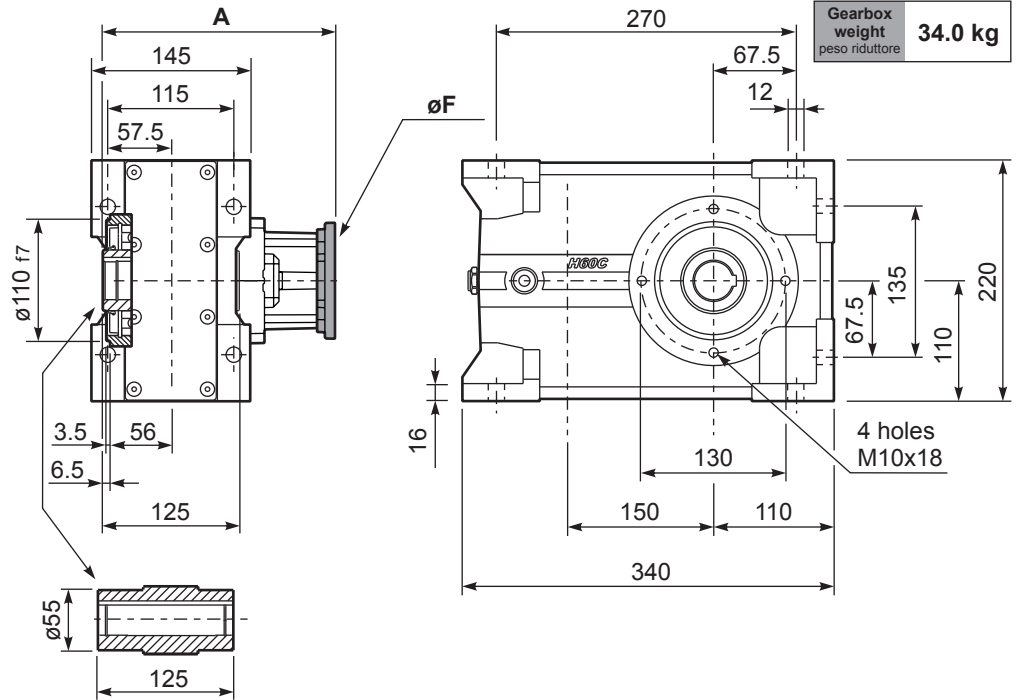
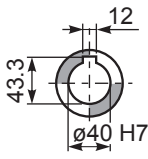

Gearbox weight  
peso riduttore **34.0 kg**

**PH62C...-F**

Output flange  
Flangia uscita

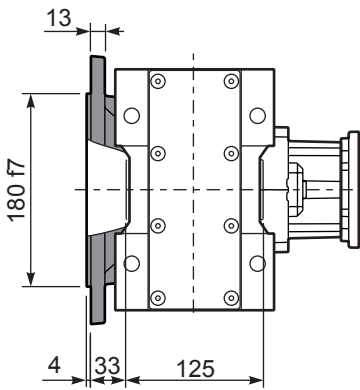

Kit. Cod KF60.9.011

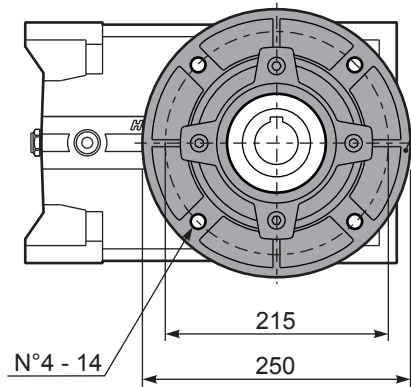

**PH62C D...**

Shrink disk  
Calettatore

Kit. Cod KF60.0.210LM

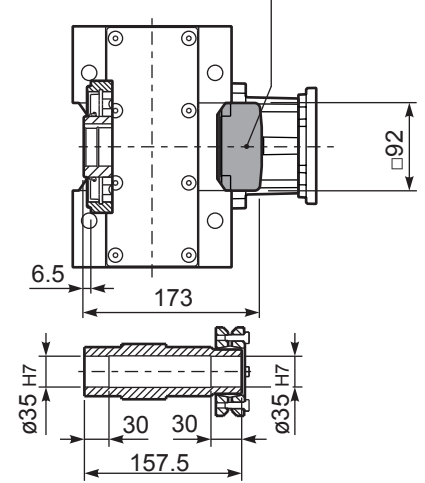

**RH62C...**

Input Shaft  
Albero in entrata

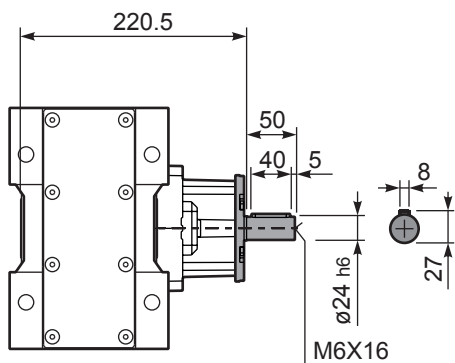

**PH62C A...**

Single output shaft  
Albero uscita semplice

