



#### QUICK SELECTION / Selezione veloce

input speed ( $n_1$ ) = 1400 min<sup>-1</sup>

Output Speed $n_2$ [min <sup>-1</sup> ]	Ratio $i$	Motor power $P_{1M}$ [kW]	Output torque $M_{2M}$ [Nm]	Service factor f.s.	Nominal power $P_{1R}$ [kW]	Nominal torque $M_{2R}$ [Nm]	Available B5 motor flanges		B14 motor flanges				Output Shaft		
							G		-	-	-	-	-	-	-
507	<b>2.76</b>	9	166	1.6	<b>14.4</b>	<b>265</b>	not available		not available				2980	<b>standard</b>	01
395	<b>3.54</b>	9	213	1.3	<b>11.6</b>	<b>275</b>							2485	<b>Ø35</b>	02
277	<b>5.06</b>	9	304	1.0	<b>8.6</b>	<b>290</b>							1891		03
241	<b>5.81</b>	7.5	281	1.2	<b>8.5</b>	<b>330</b>							1693	Ø38	04
206	<b>6.79</b>	7.5	329	1.2	<b>8.4</b>	<b>380</b>							1495	Ø40	05
The dynamic efficiency is <b>0.98</b> for all ratios											On request				

Motor Flanges Available Flange Motore Disponibili    
 B Supplied with Reduction Bushing Fornito con Bussola di Riduzione    
 B) Available on Request without reduction bushing Disponibile a Richiesta senza Bussola di Riduzione    
 C Motor Flange Holes Position Posizione Fori Flangia Motore

**EN** Unit **701C** is supplied with synthetic oil for lifetime lubrication, no maintenance is necessary. See table 1 for lubrication and recommended quantity. In table 2 please see possible radial loads and axial loads on the gearbox.

**I** Il riduttore **701C** viene fornito completo di olio sintetico per la lubrificazione permanente e non necessita di alcuna manutenzione. Vedi tab.1 per oli e quantità consigliati. In tab.2 sono presenti i carichi radiali e assiali applicabili al riduttore.

**D** Das Getriebe **701C** ist mit synthetischem Öl gefüllt und ist lebensdauergeschmiert. In Tabelle 1 ist die Schmiermenge und das empfohlene Schmiermittel angegeben. In Tabelle 2 sind die zulässigen Radial- und Axialbelastungen des Getriebes aufgeführt.

**F** Le réducteur **701C** est fourni complet avec de l'huile synthétique pour la lubrification permanente et ne nécessite aucun entretien. Voir tableau 1 concernant les huiles et les quantités conseillées. Les charges radiales et axiales applicables au réducteur sont précisées dans le tableau 2.

**E** El reductor tamaño **701C** se suministra, lubricado de por vida con aceite sintético y no requieren mantenimiento alguna. Ver tabla 1, para cantidades y aceites recomendados. En la tabla 2, se encuentran las cargas radiales y axiales admitidas por el reductor.

Standard supplied	For these mounting position specify in the order or add oil Per queste posizioni specificare in fase d'ordine o aggiungere olio					
B3	B6	B7	B8	V5	V6	V8
1.85 LT	1.40 LT	1.40 LT	1.30 LT	2.25 LT	1.60 LT	Ask
AGIP Telium VSF 320			SHELL Omala S4 WE 320			

For all details on lubrication and plugs check our website [tab. 1](#)  
Per maggiori dettagli su lubrificazione e tappi olio vedi il nostro sito web

#### RADIAL AND AXIAL LOADS

**Output shaft**  
Albero di uscita

$F_R (N)$   
 $F_A (N)$

$F_{eq} = F_R \cdot \frac{70}{X+35}$   
 $F_{eq} (N)$

$n_2$	FA	FR	$n_2$	FA	FR	$n_2$	FA	FR
300	680	3400	140	960	4800	70	1300	6500
250	760	3800	120	1040	5200	40	1460	7300
200	900	4500	85	1120	5600	15	1800	9000

**On request reinforced bearings to increase loads.**  
A richiesta cuscinetti rinforzati per aumentare i carichi.

tab. 2

P701C**S6**... With feet  
Con piedini

Gearbox weight **36.0 kg**  
peso riduttore With feet **39.5 kg**

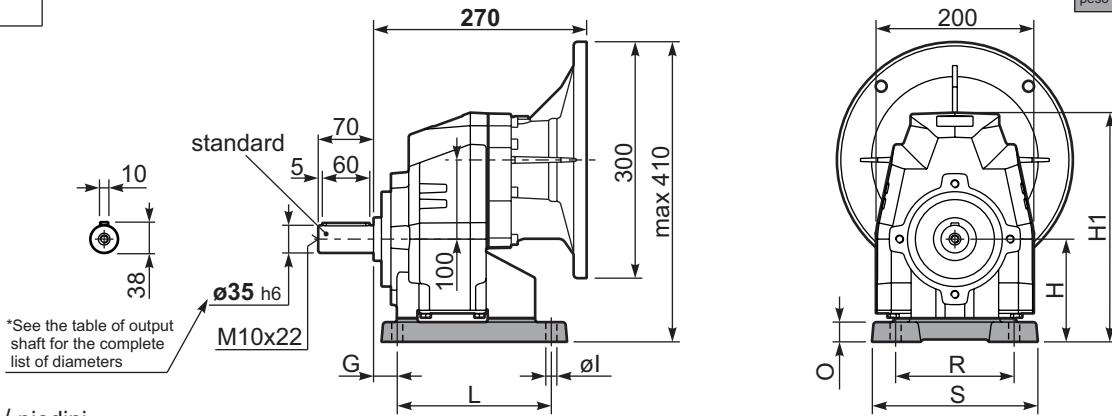

**Feet / piedini**

Feet Code	Market reference	G	H	R	L	S	H1	O	øI	B5 max. Flange	kit code
B4	412/3	19.5	130	180	149.5	216	290	25	14	-	KC70.9.022
S6	67	30	130	150	195	210	290	25	14	-	KC70.9.024
H5	025/253	35	160	170	175	220	320	30	16	-	KC70.9.023
-	-	-	-	-	-	-	-	-	-	-	-
-	-	-	-	-	-	-	-	-	-	-	-

P701C-**F**... Output flanges  
flange di uscita

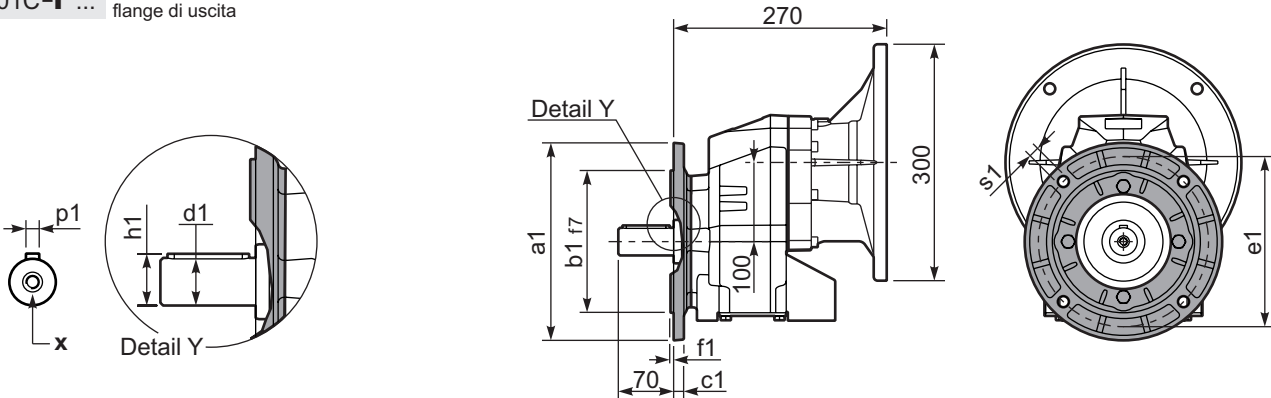

**\*Available output shaft / Albero di uscita**

	Shaft - d1	p1	h1	x
Standard	ø 35x70	10	38	M10x22
On request A richiesta	ø 38x70	10	41	M10x25
	ø 40x80	12	43	M12x28

**Available output flanges / flange di uscita**

a1 ø	b1	c1	e1	f1	s1	kit code
200	130	11	165	3.5	11	KC70.9.012
250	180	13	215	4	14	KC70.9.013
-	-	-	-	-	-	-

With flange and feet only on request. Ask for compatibility

P701C-**N**... Basic gearbox  
Riduttore base

