

PRESTAZIONI
PERFORMANCES
LEISTUNG

OT..
OT../3

	Pag. Page <i>Seite</i>
OT 56, MOT 56	16
OT 56/3, MOT 56/3	17
OT 63, MOT 63	18
OT 63/3, MOT 63/3	19
OT 80, MOT 80	20
OT 80/3, MOT 80/3	21
OT 100, MOT 100	22
OT 100/3, MOT 100/3	23
OT 125, MOT 125	24
OT 125/3, MOT 125/3	25
OT 160, MOT 160	26
OT 160/3, MOT 160/3	27
CARICHI RADIALI DELLE GRANDEZZE 80, 100, 125, 160 SIZE OVERHUNG LOADS 80, 100, 125, 160 <i>RADIALE BELASTUNGEN DER GRÖSSEN 80, 100, 125, 160</i>	28

i	n ₁	n ₂	M ₂	KW ₁	HP ₁	R.D.
9.83	2800	284,8	99	3,1	4,1	0,96
12,70		220,5	104	2,5	3,3	0,96
14,32		195,5	113	2,4	3,2	0,96
19,65		142,5	117	1,8	2,4	0,96
25,40		110,2	122	1,5	2,0	0,96
28,63		97,8	126	1,3	1,8	0,96
38,10		73,5	131	1,1	1,4	0,96
42,95		65,2	135	1,0	1,3	0,96

i	n ₁	n ₂	M ₂	KW ₁	HP ₁	R.D.	fs	P.A.M.
9.83	2800	284,8	48	1,50	2,00	0,96	2,05	80
12,70		220,5	62	1,50	2,00	0,96	1,67	80
14,32		195,5	70	1,50	2,00	0,96	1,61	80
19,65		142,5	97	1,50	2,00	0,96	1,21	80
25,40		110,2	125	1,50	2,00	0,96	0,98	80
28,63		97,8	103	1,10	1,50	0,96	1,22	80
38,10		73,5	94	0,75	1,00	0,96	1,40	71
42,95		65,2	105	0,75	1,00	0,96	1,28	71

i	n ₁	n ₂	M ₂	KW ₁	HP ₁	R.D.
9.83	1400	142,4	110	1,7	2,3	0,96
12,70		110,2	115	1,4	1,8	0,96
14,32		97,8	125	1,3	1,8	0,96
19,65		71,2	130	1,0	1,3	0,96
25,40		55,1	135	0,8	1,1	0,96
28,63		48,9	140	0,7	1,0	0,96
38,10		36,7	145	0,6	0,8	0,96
42,95		32,6	150	0,5	0,7	0,96

i	n ₁	n ₂	M ₂	KW ₁	HP ₁	R.D.	fs	P.A.M.
9.83	1400	142,4	48	0,75	1,00	0,96	2,28	80
12,70		110,2	62	0,75	1,00	0,96	1,84	80
14,32		97,8	70	0,75	1,00	0,96	1,78	80
19,65		71,2	97	0,75	1,00	0,96	1,35	80
25,40		55,1	125	0,75	1,00	0,96	1,08	80
28,63		48,9	103	0,55	0,75	0,96	1,36	80
38,10		36,7	92	0,37	0,50	0,96	1,57	71
42,95		32,6	104	0,37	0,50	0,96	1,44	71

i	n ₁	n ₂	M ₂	KW ₁	HP ₁	R.D.
9.83	900	91,6	121	1,2	1,6	0,96
12,70		70,9	127	1,0	1,3	0,96
14,32		62,8	138	0,9	1,3	0,96
19,65		45,8	143	0,7	1,0	0,96
25,40		35,4	149	0,6	0,8	0,96
28,63		31,4	154	0,5	0,7	0,96
38,10		23,6	160	0,4	0,5	0,96
42,95		21,0	165	0,4	0,5	0,96

i	n ₁	n ₂	M ₂	KW ₁	HP ₁	R.D.	fs	P.A.M.
9.83	900	91,6	55	0,55	0,75	0,96	2,20	80
12,70		70,9	71	0,55	0,75	0,96	1,78	80
14,32		62,8	80	0,55	0,75	0,96	1,72	80
19,65		45,8	110	0,55	0,75	0,96	1,30	80
25,40		35,4	142	0,55	0,75	0,96	1,05	80
28,63		31,4	108	0,37	0,50	0,96	1,43	80
38,10		23,6	97	0,25	0,33	0,96	1,65	71
42,95		21,0	109	0,25	0,33	0,96	1,51	71

DIMENSIONI DI INGOMBRO

OVERALL DIMENSIONS

ALLGEMEINE ABMESSUNGEN

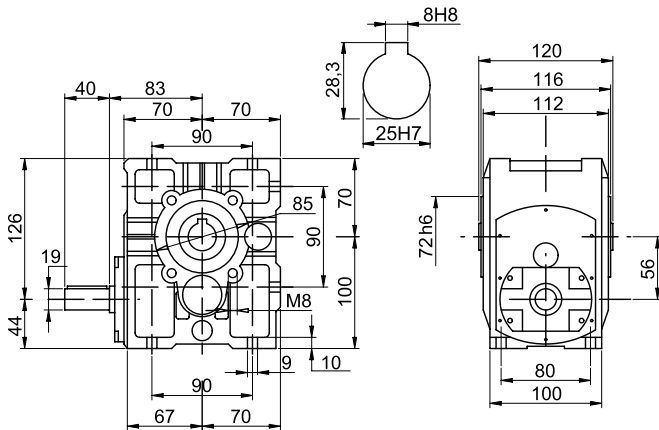

OT 56

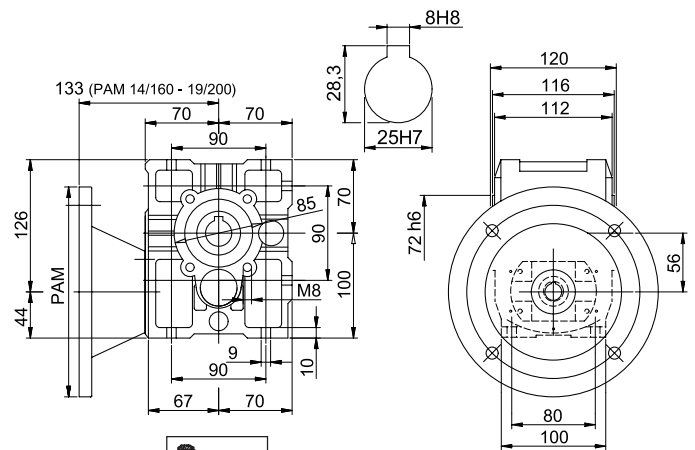
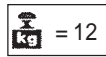

MOT 56

CARICHI RADIALI (N)

OVERHUNG LOADS (N)

RADIALE BELASTUNGEN (N)

ALBERO VELOCE/INPUT SHAFT/EINGANGSWELLE		
	OT 56	OT 56/3
1400 min ⁻¹	350	250

ALBERO LENTO/OUTPUT SHAFT/EINGANGSWELLE							
OT 56 - OT 56/3							
min ⁻¹	0°	30°	60°	90°	120°	150°	180°
20	7732	7794	8675	9721	10922	11862	12232
40	5847	6112	6738	7784	8988	9979	10349
60	4965	5174	5802	6846	8049	9040	9458
80	4337	4547	5174	6220	7422	8467	8832
100	3919	4129	4702	5744	6948	7980	8413
120	3605	3763	4389	5383	6638	7682	8100
140	3345	3491	4073	4995	6159	7128	7516
160	3135	3272	3817	4682	5773	6681	7045

Rotazione oraria
Clockwise rotation
Uhrzeigersinn

Rotazione antioraria
Anticlockwise rotation
Gegenuhrzeigersinn

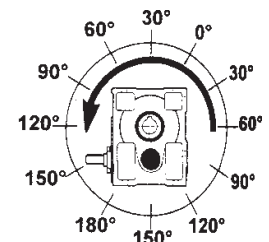
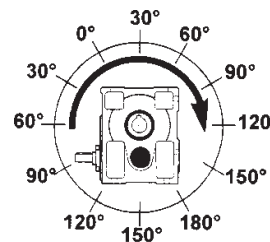

i	n ₁	n ₂	M ₂	KW ₁	HP ₁	R.D.
53,72	2800	52,1	135	0,8	1,1	0,92
60,56		46,2	135	0,7	0,9	0,92
65,15		43,0	135	0,7	0,9	0,92
75,60		37,0	135	0,6	0,8	0,92
80,58		34,7	144	0,6	0,8	0,92
90,84		30,8	149	0,5	0,7	0,92
95,63		29,3	153	0,5	0,7	0,92
110,17		25,4	153	0,4	0,6	0,92
143,44		19,5	158	0,4	0,5	0,92
161,72		17,3	162	0,3	0,4	0,92

i	n ₁	n ₂	M ₂	KW ₁	HP ₁	R.D.	fs	P.A.M.
53,72	2800	52,1	126	0,75	1,00	0,92	1,07	71
60,56		46,2	143	0,75	1,00	0,92	0,95	71
65,15		43,0	51	0,25	0,33	0,92	2,64	63
75,60		37,0	59	0,25	0,33	0,92	2,28	63
80,58		34,7	139	0,55	0,75	0,92	1,04	71
90,84		30,8	157	0,55	0,75	0,92	0,95	71
95,63		29,3	75	0,25	0,33	0,92	2,04	63
110,17		25,4	86	0,25	0,33	0,92	1,77	63
143,44		19,5	113	0,25	0,33	0,92	1,40	63
161,72		17,3	127	0,25	0,33	0,92	1,28	63

53,72	1400	26,1	150	0,4	0,6	0,92
60,56		23,1	150	0,4	0,5	0,92
65,15		21,5	150	0,4	0,5	0,92
75,60		18,5	150	0,3	0,4	0,92
80,58		17,4	160	0,3	0,4	0,92
90,84		15,4	165	0,3	0,4	0,92
95,63		14,6	170	0,3	0,4	0,92
110,17		12,7	170	0,2	0,3	0,92
143,44		9,8	175	0,2	0,3	0,92
161,72		8,7	180	0,2	0,2	0,92

53,72	1400	26,1	125	0,37	0,50	0,92	1,20	71
60,56		23,1	141	0,37	0,50	0,92	1,07	71
65,15		21,5	74	0,18	0,25	0,92	2,04	63
75,60		18,5	85	0,18	0,25	0,92	1,76	63
80,58		17,4	126	0,25	0,33	0,92	1,27	71
90,84		15,4	143	0,25	0,33	0,92	1,16	71
95,63		14,6	108	0,18	0,25	0,92	1,57	63
110,17		12,7	124	0,18	0,25	0,92	1,37	63
143,44		9,8	162	0,18	0,25	0,92	1,08	63
161,72		8,7	183	0,18	0,25	0,92	0,99	63

53,72	900	16,8	165	0,3	0,4	0,92
60,56		14,9	165	0,3	0,4	0,92
65,15		13,8	165	0,3	0,3	0,92
75,60		11,9	165	0,2	0,3	0,92
80,58		11,2	176	0,2	0,3	0,92
90,84		9,9	182	0,2	0,3	0,92
95,63		9,4	187	0,2	0,3	0,92
110,17		8,2	187	0,2	0,2	0,92
143,44		6,3	193	0,1	0,2	0,92
161,72		5,6	198	0,1	0,2	0,92

53,72	900	16,8	131	0,25	0,33	0,92	1,26	71
60,56		14,9	148	0,25	0,33	0,92	1,12	71
65,15		13,8	76	0,12	0,16	0,92	2,16	63
75,60		11,9	89	0,12	0,16	0,92	1,86	63
80,58		11,2	197	0,25	0,33	0,92	0,89	71
90,84		9,9	160	0,18	0,25	0,92	1,14	71
95,63		9,4	112	0,12	0,16	0,92	1,67	63
110,17		8,2	129	0,12	0,16	0,92	1,45	63
143,44		6,3	168	0,12	0,16	0,92	1,15	63
161,72		5,6	189	0,12	0,16	0,92	1,05	63

DIMENSIONI DI INGOMBRO

OVERALL DIMENSIONS

ALLGEMEINE ABMESSUNGEN

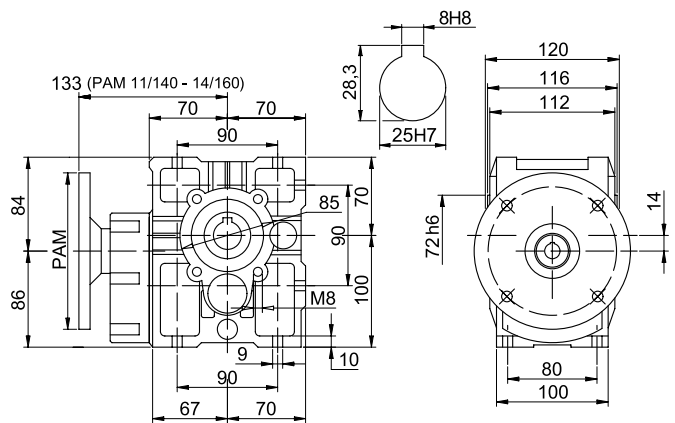
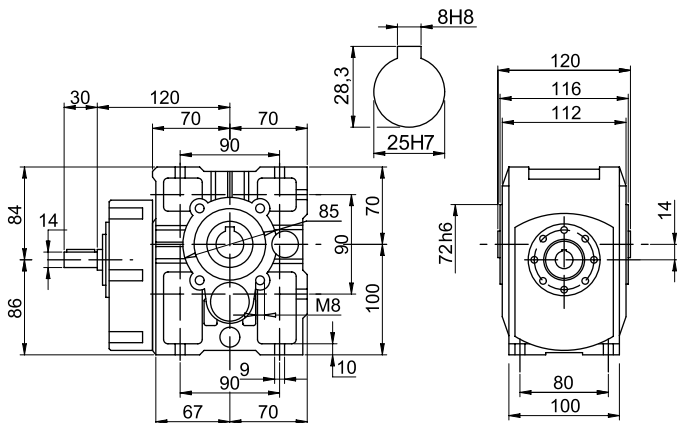

OT 56/3

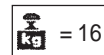
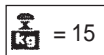

MOT 56/3

i	n ₁	n ₂	M ₂	KW ₁	HP ₁	R.D.
10,16	2800	275,6	180	5,4	7,2	0,96
13,08		214,1	180	4,2	5,6	0,96
14,38		194,7	180	3,8	5,1	0,96
20,31		137,9	216	3,2	4,3	0,96
26,15		107,1	207	2,4	3,2	0,96
28,75		97,4	207	2,2	2,9	0,96
41,07		68,2	207	1,5	2,1	0,96
51,19		54,7	180	1,1	1,4	0,96

i	n ₁	n ₂	M ₂	KW ₁	HP ₁	R.D.	fs	P.A.M.
10,16	2800	275,6	73	2,20	3,00	0,96	2,46	80 90
13,08		214,1	94	2,20	3,00	0,96	1,91	80 90
14,38		194,7	104	2,20	3,00	0,96	1,74	80 90
20,31		137,9	146	2,20	3,00	0,96	1,48	80 90
26,15		107,1	188	2,20	3,00	0,96	1,10	80 90
28,75		97,4	207	2,20	3,00	0,96	1,00	80 90
41,07		68,2	148	1,10	1,50	0,96	1,40	80
51,19		54,7	184	1,10	1,50	0,96	0,98	80

10,16	1400	137,8	200	3,0	4,0	0,96
13,08		107,0	200	2,3	3,1	0,96
14,38		97,4	200	2,1	2,8	0,96
20,31		68,9	240	1,8	2,4	0,96
26,15		53,5	230	1,3	1,8	0,96
28,75		48,7	230	1,2	1,6	0,96
41,07		34,1	230	0,9	1,1	0,96
51,19		27,3	200	0,6	0,8	0,96

10,16	1400	137,8	120	1,80	2,50	0,96	1,67	80 90
13,08		107,0	154	1,80	2,50	0,96	1,30	80 90
14,38		97,4	170	1,80	2,50	0,96	1,18	80 90
20,31		68,9	239	1,80	2,00	0,96	1,00	80 90
26,15		53,5	257	1,50	2,00	0,96	0,90	80 90
28,75		48,7	207	1,10	1,50	0,96	1,11	80 90
41,07		34,1	202	0,75	1,00	0,96	1,14	80
51,19		27,3	251	0,75	1,00	0,96	0,80	80

10,16	900	88,6	220	2,1	2,8	0,96
13,08		68,8	220	1,7	2,2	0,96
14,38		62,6	220	1,5	2,0	0,96
20,31		44,3	264	1,3	1,7	0,96
26,15		34,4	253	0,9	1,3	0,96
28,75		31,3	253	0,9	1,2	0,96
41,07		21,9	253	0,6	0,8	0,96
51,19		17,6	220	0,4	0,6	0,96

10,16	900	88,6	114	1,10	1,50	0,96	1,93	80 90
13,08		68,8	147	1,10	1,50	0,96	1,50	80 90
14,38		62,6	161	1,10	1,50	0,96	1,37	80 90
20,31		44,3	228	1,10	1,50	0,96	1,16	80 90
26,15		34,4	200	0,75	1,00	0,96	1,27	80 90
28,75		31,3	220	0,75	1,00	0,96	1,15	80 90
41,07		21,9	230	0,55	0,75	0,96	1,10	80
51,19		17,6	287	0,55	0,75	0,96	0,77	80

DIMENSIONI DI INGOMBRO

OVERALL DIMENSIONS

ALLGEMEINE ABMESSUNGEN

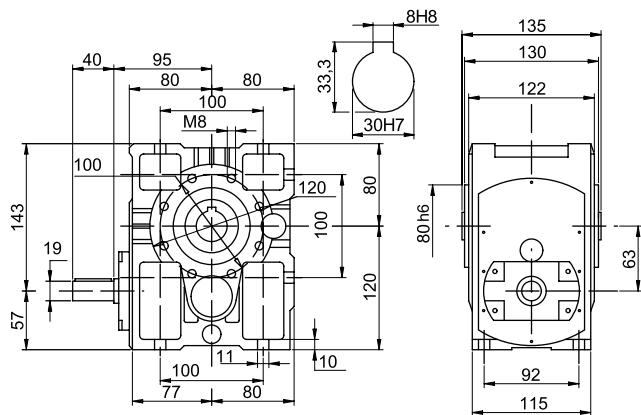
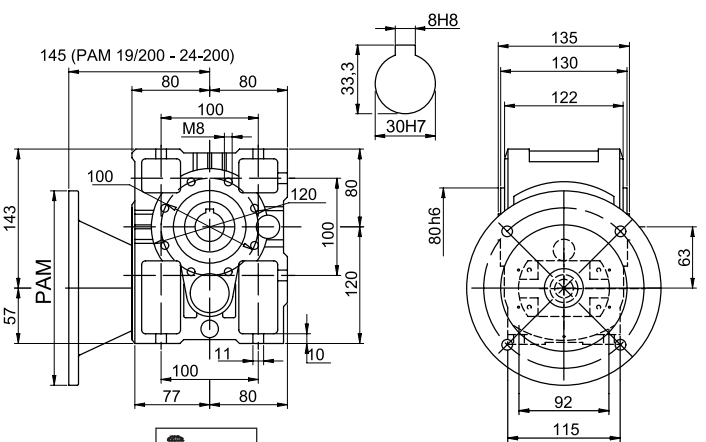
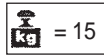
OT 63

MOT 63

CARICHI RADIALI (N)

OVERHUNG LOADS (N)

RADIALE BELASTUNGEN (N)

ALBERO VELOCE/INPUT SHAFT/EINGANGSWELLE		
1400 min ⁻¹	OT 63	OT 63/3
	550	400

ALBERO LENTO/OUTPUT SHAFT/EINGANGSWELLE							
OT 63 - OT 63/3							
min ⁻¹	0°	30°	60°	90°	120°	150°	180°
20	9205	9517	10327	11572	13002	14121	14562
40	6961	7276	8022	9267	10700	11880	12320
60	5911	6159	6907	8150	9582	10762	11259
80	5164	5413	6159	7404	8836	10079	10514
100	4666	4916	5598	6838	8271	9500	10016
120	4291	4480	5225	6409	7902	9145	9643
140	3982	4156	4848	5946	7332	8486	8948
160	3732	3896	4544	5574	6872	7954	8386

 Rotazione oraria
 Clockwise rotation
 Uhrzeigersinn

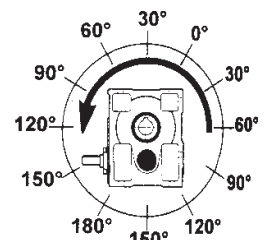
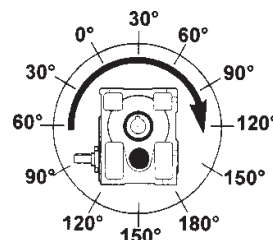
 Rotazione antioraria
 Anticlockwise rotation
 Gegenuhrzeigersinn

i	n ₁	n ₂	M ₂	KW ₁	HP ₁	R.D.
16,54	2800	169,3	216	4,2	5,5	0,92
21,30		131,5	243	3,6	4,8	0,92
23,41		119,6	234	3,2	4,2	0,92
33,08		84,6	252	2,4	3,2	0,92
42,59		65,7	270	2,0	2,7	0,92
46,82		59,8	252	1,7	2,3	0,92
58,36		48,0	198	1,1	1,4	0,92
94,84		29,5	234	0,8	1,0	0,92
104,26		26,9	234	0,7	1,0	0,92
129,95		21,5	207	0,5	0,7	0,92
147,86		18,9	243	0,5	0,7	0,92
184,30		15,2	216	0,4	0,5	0,92

i	n ₁	n ₂	M ₂	KW ₁	HP ₁	R.D.	fs	P.A.M.	
16,54	2800	169,3	78	1,50	2,00	0,92	2,77	71	80
21,30		131,5	100	1,50	2,00	0,92	2,42	71	80
23,41		119,6	110	1,50	2,00	0,92	2,12	71	80
33,08		84,6	156	1,50	2,00	0,92	1,62	71	80
42,59		65,7	200	1,50	2,00	0,92	1,35	71	80
46,82		59,8	220	1,50	2,00	0,92	1,14	71	80
58,36		48,0	201	1,10	1,50	0,92	0,98	71	80
94,84		29,5	223	0,75	1,00	0,92	1,05	71	
104,26		26,9	180	0,55	0,75	0,92	1,30	71	
129,95		21,5	151	0,37	0,50	0,92	1,37	71	
147,86		18,9	172	0,37	0,50	0,92	1,42	63	71
184,30		15,2	214	0,37	0,50	0,92	1,01	63	71

16,54	1400	84,6	240	2,3	3,1	0,92
21,30		65,7	270	2,0	2,7	0,92
23,41		59,8	260	1,8	2,4	0,92
33,08		42,3	280	1,3	1,8	0,92
42,59		32,9	300	1,1	1,5	0,92
46,82		29,9	280	1,0	1,3	0,92
58,36		24,0	220	0,6	0,8	0,92
94,84		14,8	260	0,4	0,6	0,92
104,26		13,4	260	0,4	0,5	0,92
129,95		10,8	230	0,3	0,4	0,92
147,86		9,5	270	0,3	0,4	0,92
184,30		7,6	240	0,2	0,3	0,92

16,54	1400	84,6	78	0,75	1,00	0,92	3,08	71	80
21,30		65,7	100	0,75	1,00	0,92	2,69	71	80
23,41		59,8	110	0,75	1,00	0,92	2,36	71	80
33,08		42,3	156	0,75	1,00	0,92	1,80	71	80
42,59		32,9	200	0,75	1,00	0,92	1,50	71	80
46,82		29,9	220	0,75	1,00	0,92	1,27	71	80
58,36		24,0	201	0,55	0,75	0,92	1,09	71	80
94,84		14,8	220	0,37	0,50	0,92	1,18	71	
104,26		13,4	242	0,37	0,50	0,92	1,07	71	
129,95		10,8	302	0,37	0,50	0,92	0,76	71	
147,86		9,5	232	0,25	0,33	0,92	1,16	63	71
184,30		7,6	289	0,25	0,33	0,92	0,83	63	71

16,54	900	54,4	264	1,6	2,2	0,92
21,30		42,3	297	1,4	1,9	0,92
23,41		38,4	286	1,3	1,7	0,92
33,08		27,2	308	1,0	1,3	0,92
42,59		21,1	330	0,8	1,1	0,92
46,82		19,2	308	0,7	0,9	0,92
58,36		15,4	242	0,4	0,6	0,92
94,84		9,5	286	0,3	0,4	0,92
104,26		8,6	286	0,3	0,4	0,92
129,95		6,9	253	0,2	0,3	0,92
147,86		6,1	297	0,2	0,3	0,92
184,30		4,9	264	0,1	0,2	0,92

16,54	900	54,4	89	0,55	0,75	0,92	2,97	71	80
21,30		42,3	114	0,55	0,75	0,92	2,60	71	80
23,41		38,4	126	0,55	0,75	0,92	2,28	71	80
33,08		27,2	178	0,55	0,75	0,92	1,73	71	80
42,59		21,1	229	0,55	0,75	0,92	1,44	71	80
46,82		19,2	251	0,55	0,75	0,92	1,23	71	80
58,36		15,4	211	0,37	0,50	0,92	1,15	71	80
94,84		9,5	231	0,25	0,33	0,92	1,24	71	
104,26		8,6	254	0,25	0,33	0,92	1,12	71	
129,95		6,9	317	0,25	0,33	0,92	0,80	71	
147,86		6,1	260	0,18	0,25	0,92	1,14	63	71
184,30		4,9	324	0,18	0,25	0,92	0,82	63	71

DIMENSIONI DI INGOMBRO

OVERALL DIMENSIONS

ALLGEMEINE ABMESSUNGEN

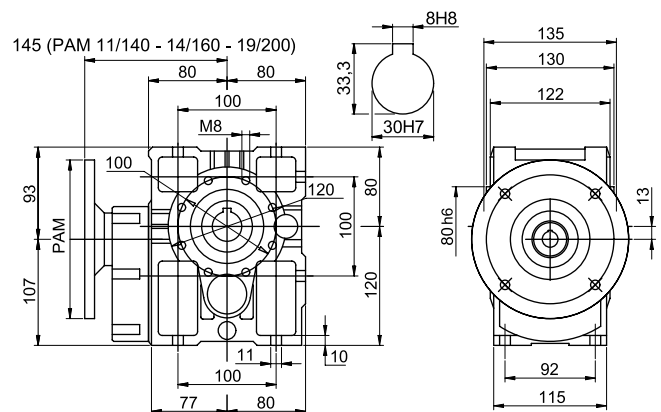
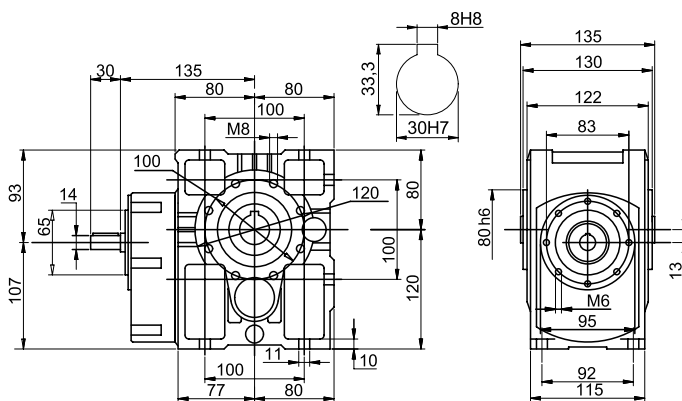
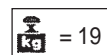
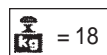
OT 63/3

MOT 63/3

OT 80

PRESTAZIONI

PERFORMANCES

LEISTUNG

MOT 80

i	n ₁	n ₂	M ₂	KW ₁	HP ₁	R.D.
9,53	2800	293,8	398	12,7	17,0	0,96
12,31		227,5	513	12,7	17,0	0,96
15,00		186,7	442	9,0	12,0	0,96
19,06		146,9	451	7,2	9,6	0,96
24,62		113,7	510	6,3	8,4	0,96
30,00		93,3	445	4,5	6,0	0,96
43,33		64,6	408	2,9	3,8	0,96
55,37		50,6	408	2,3	3,0	0,96

i	n ₁	n ₂	M ₂	KW ₁	HP ₁	R.D.	fs	P.A.M.
9,53	2800	293,8	172	5,5	7,5	0,96	2,32	90 100
12,31		227,5	222	5,5	7,5	0,96	2,32	90 100
15,00		186,7	270	5,5	7,5	0,96	1,64	90 100
19,06		146,9	343	5,5	7,5	0,96	1,31	90 100
24,62		113,7	443	5,5	7,5	0,96	1,15	90 100
30,00		93,3	393	4,0	5,5	0,96	1,13	90 100
43,33		64,6	312	2,2	3,0	0,96	1,31	90
55,37		50,6	399	2,2	3,0	0,96	1,02	90

9,53	1400	146,9	468	7,5	10,0	0,96
12,31		113,7	604	7,5	10,0	0,96
15,00		93,3	520	5,3	7,1	0,96
19,06		73,4	530	4,2	5,7	0,96
24,62		56,9	600	3,7	5,0	0,96
30,00		46,7	523	2,7	3,5	0,96
43,33		32,3	480	1,7	2,3	0,96
55,37		25,3	480	1,3	1,8	0,96

9,53	1400	146,9	250	4,0	5,5	0,96	1,87	90 100
12,31		113,7	322	4,0	5,5	0,96	1,87	90 100
15,00		93,3	393	4,0	5,5	0,96	1,32	90 100
19,06		73,4	499	4,0	5,5	0,96	1,06	90 100
24,62		56,9	484	3,0	4,0	0,96	1,24	90 100
30,00		46,7	432	2,2	3,0	0,96	1,21	90 100
43,33		32,3	426	1,5	2,0	0,96	1,13	90
55,37		25,3	399	1,1	1,5	0,96	1,20	90

9,53	900	94,4	515	5,3	7,1	0,96
12,31		73,1	664	5,3	7,1	0,96
15,00		60,0	572	3,7	5,0	0,96
19,06		47,2	583	3,0	4,0	0,96
24,62		36,6	660	2,6	3,5	0,96
30,00		30,0	575	1,9	2,5	0,96
43,33		20,8	528	1,2	1,6	0,96
55,37		16,3	528	0,9	1,2	0,96

9,53	900	94,4	291	3,0	4,0	0,96	1,77	90 100
12,31		73,1	376	3,0	4,0	0,96	1,77	90 100
15,00		60,0	458	3,0	4,0	0,96	1,25	90 100
19,06		47,2	583	3,0	4,0	0,96	1,00	90 100
24,62		36,6	502	2,0	2,7	0,96	1,32	90 100
30,00		30,0	611	2,0	2,7	0,96	0,94	90 100
43,33		20,8	486	1,1	1,5	0,96	1,09	90
55,37		16,3	620	1,1	1,5	0,96	0,85	90

DIMENSIONI DI INGOMBRO

OVERALL DIMENSIONS

ALLGEMEINE ABMESSUNGEN

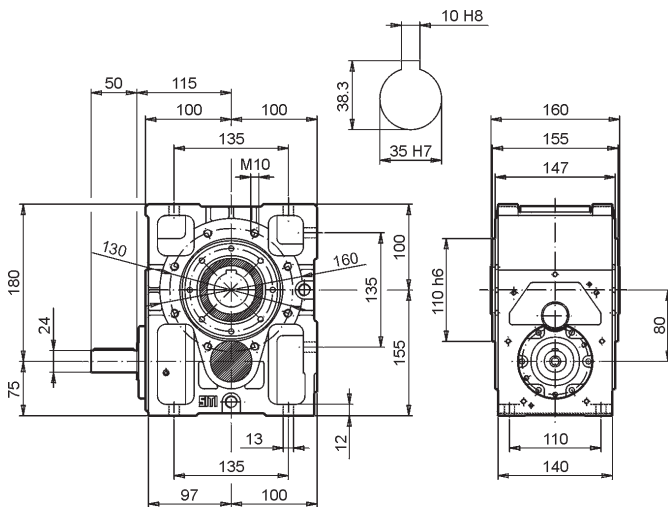

OT 80 = 26

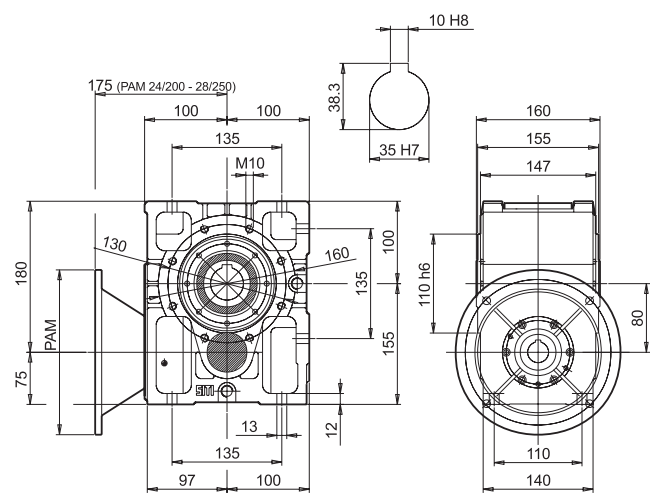

MOT 80 = 29

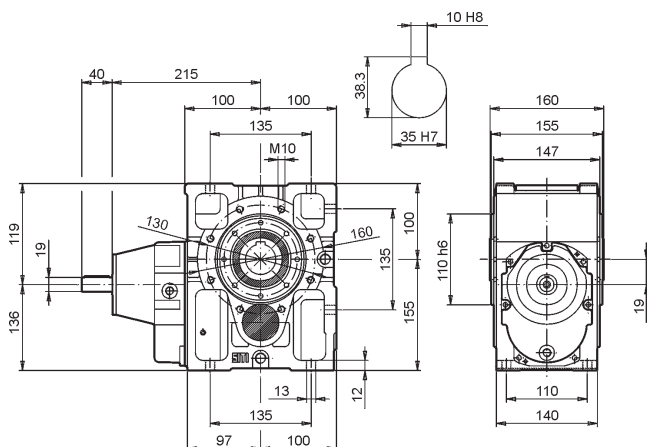

OT 80/3 = 33

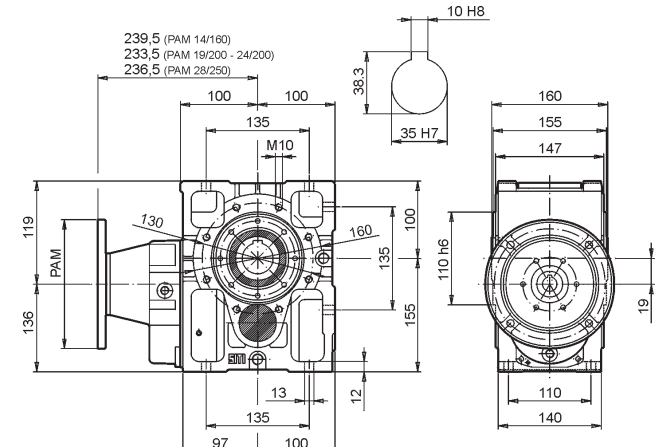

MOT 80/3 = 35

i	n ₁	n ₂	M ₂	KW ₁	HP ₁	R. D.
32,17	2800	87,0	527	5,2	7,0	0,92
38,13		73,4	527	4,4	5,9	0,92
43,14		64,9	527	3,9	5,2	0,92
49,33		56,8	527	3,4	4,5	0,92
57,19		49,0	527	2,9	3,9	0,92
67,45		41,5	527	2,5	3,3	0,92
83,08		33,7	510	2,0	2,6	0,92
98,46		28,4	510	1,7	2,2	0,92
111,41		25,1	510	1,5	1,9	0,92
127,41		22,0	510	1,3	1,7	0,92
147,69		19,0	510	1,1	1,5	0,92
174,2		16,1	510	0,9	1,2	0,92
208,12		13,5	510	0,8	1,0	0,92
233,85		12,0	510	0,7	0,9	0,92
262,57		10,7	510	0,6	0,8	0,92
306,67		9,1	425	0,4	0,6	0,92
366,38		7,6	425	0,4	0,5	0,92
411,67		6,8	425	0,3	0,4	0,92
462,24		6,1	425	0,3	0,4	0,92

i	n ₁	n ₂	M ₂	KW ₁	HP ₁	R. D.	fs	P. A. M.		
32,17	2800	87,0	404	4	5,5	0,92	1,31		90	100
38,13		73,4	479	4	5,5	0,92	1,10	80	90	100
43,14		64,9	406	3	4,0	0,92	1,30	80	90	100
49,33		56,8	341	2,2	3,0	0,92	1,55	80	90	
57,19		49,0	395	2,2	3,0	0,92	1,33	71	80	90
67,45		41,5	466	2,2	3,0	0,92	1,13	71	80	90
83,08		33,7	391	1,5	2,0	0,92	1,30		90	100
98,46		28,4	463	1,5	2,0	0,92	1,10		80	90
111,41		25,1	385	1,1	1,5	0,92	1,33		80	90
127,41		22,0	440	1,1	1,5	0,92	1,16		80	90
147,69		19,0	510	1,1	1,5	0,92	1,00	71	80	90
174,20		16,1	410	0,75	1,0	0,92	1,24	71	80	90
208,12		13,5	490	0,75	1,0	0,92	1,04	71	80	
233,85		12,0	404	0,55	0,75	0,92	1,26	71	80	
262,57		10,7	453	0,55	0,75	0,92	1,13	71	80	
306,67		9,1	356	0,37	0,5	0,92	1,19	71	80	90
366,38		7,6	425	0,37	0,5	0,92	1,00	71	80	
411,67		6,8	478	0,37	0,5	0,92	0,89	71	80	
462,24		6,1	537	0,37	0,5	0,92	0,79	71	80	

32,17	1400	43,5	620	3,1	4,1	0,92
38,13		36,7	620	2,6	3,5	0,92
43,14		32,5	620	2,3	3,1	0,92
49,33		28,4	620	2,0	2,7	0,92
57,19		24,5	620	1,7	2,3	0,92
67,45		20,8	620	1,5	2,0	0,92
83,08		16,9	600	1,2	1,5	0,92
98,46		14,2	600	1,0	1,3	0,92
111,41		12,6	600	0,9	1,1	0,92
127,41		11,0	600	0,8	1,0	0,92
147,69		9,5	600	0,6	0,9	0,92
174,2		8,0	600	0,5	0,7	0,92
208,12		6,7	600	0,5	0,6	0,92
233,85		6,0	600	0,4	0,5	0,92
262,57		5,3	600	0,4	0,5	0,92
306,67		4,6	500	0,3	0,3	0,92
366,38		3,8	500	0,2	0,3	0,92
411,67		3,4	500	0,2	0,3	0,92
462,24		3,0	500	0,2	0,2	0,92

32,17	1400	43,5	606	3	4,0	0,92	1,02		90	100	
38,13		36,7	526	2,2	3,0	0,92	1,18		80	90	100
43,14		32,5	596	2,2	3,0	0,92	1,04		80	90	100
49,33		28,4	464	1,5	2,0	0,92	1,34		80	90	
57,19		24,5	538	1,5	2,0	0,92	1,15	71	80	90	
67,45		20,8	635	1,5	2,0	0,92	0,98	71	80	90	
83,08		16,9	574	1,1	1,5	0,92	1,05		90	100	
98,46		14,2	568	0,92	1,2	0,92	1,06		80	90	
111,41		12,6	524	0,75	1,0	0,92	1,14		80	90	
127,41		11,0	600	0,75	1,0	0,92	1,00		80	90	
147,69		9,5	510	0,55	0,75	0,92	1,18	71	80	90	
174,20		8,0	601	0,55	0,75	0,92	1,00	71	80	90	
208,12		6,7	483	0,37	0,5	0,92	1,24	71	80		
233,85		6,0	543	0,37	0,5	0,92	1,10	71	80		
262,57		5,3	610	0,37	0,5	0,92	0,98	71	80		
306,67		4,6	481	0,25	0,33	0,92	1,04	71	80	90	
366,38		3,8	575	0,25	0,33	0,92	0,87	71	80		
411,67		3,4	646	0,25	0,33	0,92	0,77	71	80		
462,24		3,0	725	0,25	0,33	0,92	0,69	71	80		

32,17	900	28,0	682	2,2	2,9	0,92
38,13		23,6	682	1,8	2,4	0,92
43,14		20,9	682	1,6	2,2	0,92
49,33		18,2	682	1,4	1,9	0,92
57,19		15,7	682	1,2	1,6	0,92
67,45		13,3	682	1,0	1,4	0,92
83,08		10,8	660	0,8	1,1	0,92
98,46		9,1	660	0,7	0,9	0,92
111,41		8,1	660	0,6	0,8	0,92
127,41		7,1	660	0,5	0,7	0,92
147,69		6,1	660	0,5	0,6	0,92
174,2		5,2	660	0,4	0,5	0,92
208,12		4,3	660	0,3	0,4	0,92
233,85		3,8	660	0,3	0,4	0,92
262,57		3,4	660	0,3	0,3	0,92
306,67		2,9	550	0,2	0,2	0,92
366,38		2,5	550	0,2	0,2	0,92
411,67		2,2	550	0,1	0,2	0,92
462,24		1,9	550	0,1	0,2	0,92

32,17	900	28,0	471	1,5	2,0	0,92	1,45		90	100	
38,13		23,6	558	1,5	2,0	0,92	1,22		80	90	100
43,14		20,9	632	1,5	2,0	0,92	1,08		80	90	100
49,33		18,2	530	1,1	1,5	0,92	1,29		80	90	
57,19		15,7	614	1,1	1,5	0,92	1,11	71	80	90	
67,45		13,3	494	0,75	1,0	0,92	1,38	71	80	90	
83,08		10,8	608	0,75	1,0	0,92	1,09		90	100	
98,46		9,1	529	0,55	0,75	0,92	1,25		80	90	
111,41		8,1	598	0,55	0,75	0,92	1,10		80	90	
127,41		7,1	460	0,37	0,5	0,92	1,43		80	90	
147,69		6,1	533	0,37	0,5	0,92	1,24	71	80	90	
174,20		5,2	629	0,37	0,5	0,92	1,05	71	80	90	
208,12		4,3	508	0,25	0,33	0,92	1,30	71	80		
233,85		3,8	571	0,25	0,33	0,92	1,16	71	80		
262,57		3,4	641	0,25	0,33	0,92	1,03	71	80		
306,67		2,9	539	0,18	0,25	0,92	1,02	71	80	90	
366,38		2,5	644	0,18	0,25	0,92	0,85	71	80		
411,67		2,2	723	0,18	0,25	0,92	0,76	71	80		
462,24		1,9	812	0,18	0,25	0,92	0,68	71	80		

OT 100

PRESTAZIONI

PERFORMANCES

LEISTUNG

MOT 100

i	n ₁	n ₂	M ₂	KW ₁	HP ₁	R.D.
9.53	2800	293.8	705.5	22.6	30.1	0.96
12.31		227.5	754.0	18.7	24.9	0.96
15.00		186.7	867.0	17.7	23.5	0.96
19.06		146.9	892.5	14.3	19.1	0.96
24.62		113.7	977.5	12.1	16.2	0.96
30.00		93.3	867.0	8.8	11.8	0.96
43.33		64.6	790.5	5.6	7.4	0.96
56.46		49.6	740.0	4.0	5.3	0.96

i	n ₁	n ₂	M ₂	KW ₁	HP ₁	R.D.	fs	P.A.M.
9.53	2800	293.8	343	11	15.0	0.96	2.06	100 132
12.31		227.5	443	11	15.0	0.96	1.70	100 132
15.00		186.7	540	11	15.0	0.96	1.60	100 132
19.06		146.9	687	11	15.0	0.96	1.30	100 132
24.62		113.7	887	11	15.0	0.96	1.10	100 132
30.00		93.3	737	7.5	10.0	0.96	1.18	100 132
43.33		64.6	780	5.5	7.5	0.96	1.01	100 100
56.46		49.6	740	4	5.5	0.96	1.00	100

9.53	1400	146.9	830	13.3	17.7	0.96
12.31		113.7	887	11.0	14.7	0.96
15.00		93.3	1020	10.4	13.8	0.96
19.06		73.4	1050	8.4	11.2	0.96
24.62		56.9	1150	7.1	9.5	0.96
30.00		46.7	1020	5.2	6.9	0.96
43.33		32.3	930	3.3	4.4	0.96
56.46		24.8	880	2.4	3.2	0.96

9.53	1400	146.9	687	11	15.0	0.96	1.21	100 132
12.31		113.7	887	11	15.0	0.96	1.00	100 132
15.00		93.3	904	9.2	12.5	0.96	1.13	100 132
19.06		73.4	936	7.5	10.0	0.96	1.12	100 132
24.62		56.9	1209	7.5	10.0	0.96	0.95	100 132
30.00		46.7	786	4	5.5	0.96	1.30	100 132
43.33		32.3	851	3	4.0	0.96	1.09	100 100
56.46		24.8	813	2.2	3.0	0.96	1.08	100

9.53	900	94.4	913	9.4	12.5	0.96
12.31		73.1	976	7.8	10.4	0.96
15.00		60.0	1122	7.3	9.8	0.96
19.06		47.2	1155	5.9	7.9	0.96
24.62		36.6	1265	5.0	6.7	0.96
30.00		30.0	1122	3.7	4.9	0.96
43.33		20.8	1023	2.3	3.1	0.96
56.46		15.9	968	1.7	2.2	0.96

9.53	900	94.4	534	5.5	7.5	0.96	1.71	100 132
12.31		73.1	690	5.5	7.5	0.96	1.41	100 132
15.00		60.0	840	5.5	7.5	0.96	1.34	100 132
19.06		47.2	1068	5.5	7.5	0.96	1.08	100 132
24.62		36.6	1003	4	5.5	0.96	1.26	100 132
30.00		30.0	917	3	4.0	0.96	1.22	100 132
43.33		20.8	971	2.2	3.0	0.96	1.05	100 100
56.46		15.9	863	1.5	2.0	0.96	1.12	100

DIMENSIONI DI INGOMBRO

OVERALL DIMENSIONS

ALLGEMEINE ABMESSUNGEN

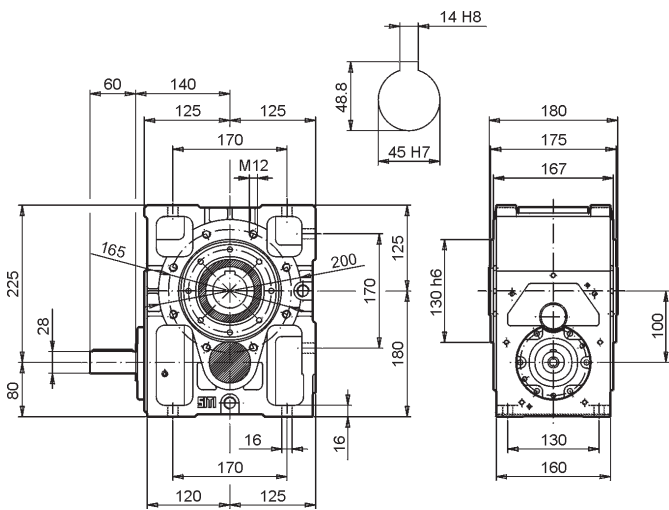

OT 100

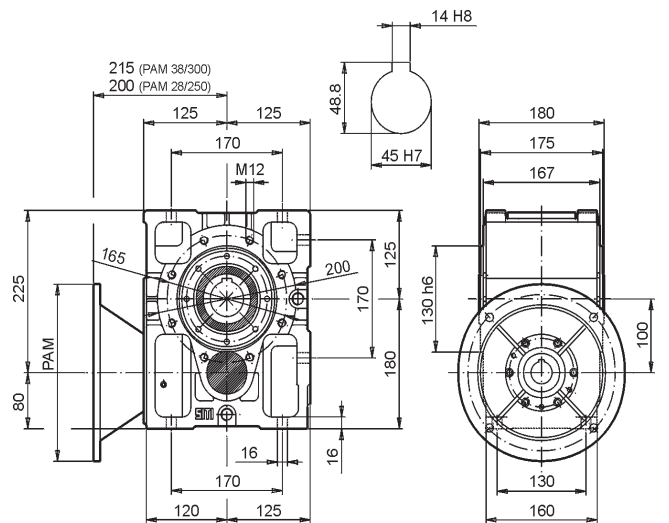
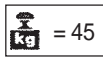

MOT 100

49

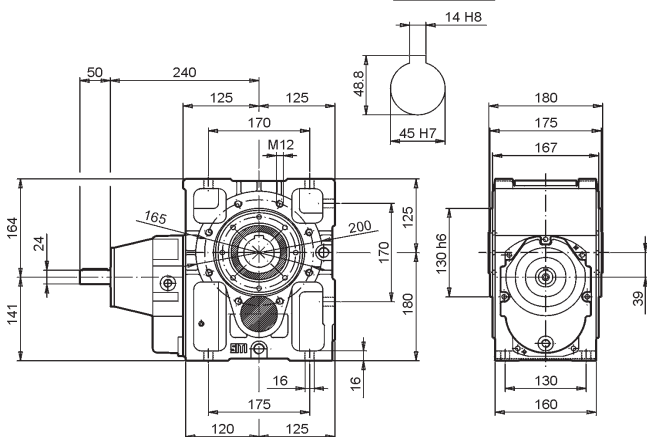

OT 100/3

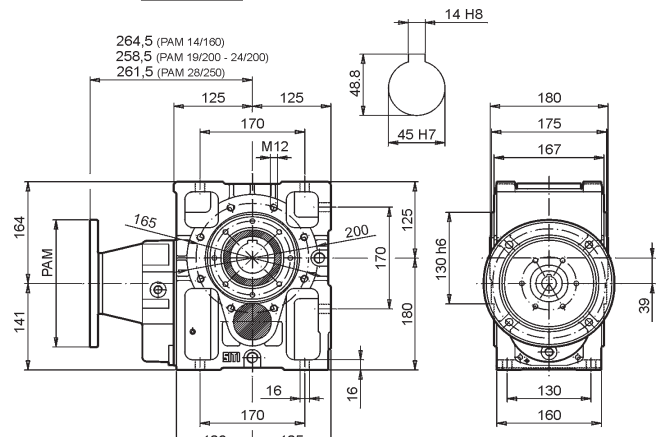
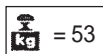

MOT 100/3

55

i	n ₁	n ₂	M ₂	KW ₁	HP ₁	R.D.
32,17	2800	87,0	957	9,48	12,6	0,92
38,13		73,4	1148	9,59	12,8	0,92
43,14		64,9	1148	8,48	11,3	0,92
49,33		56,8	1148	7,41	9,9	0,92
57,19		49,0	1037	5,78	7,7	0,92
67,45		41,5	893	4,22	5,6	0,92
83,08		33,7	1020	3,91	5,2	0,92
98,46		28,4	1020	3,30	4,4	0,92
111,41		25,1	1020	2,92	3,9	0,92
127,41		22,0	1020	2,55	3,4	0,92
147,69		19,0	1020	2,20	2,9	0,92
174,20		16,1	1020	1,87	2,5	0,92
208,12		13,5	1020	1,56	2,1	0,92
233,85		12,0	1020	1,39	1,9	0,92
262,57		10,7	1020	1,24	1,7	0,92
306,66		9,1	791	0,82	1,1	0,92
366,38		7,6	791	0,69	0,9	0,92
411,67		6,8	791	0,61	0,8	0,92
462,24	6,1	791	0,55	0,7	0,92	

i	n ₁	n ₂	M ₂	KW ₁	HP ₁	R.D.	fs	P.A.M.			
32,17	2800	87,0	555	5,5	7,5	0,92	1,72		90	100	
38,13		73,4	658	5,5	7,5	0,92	1,74	80	90	100	
43,14		64,9	745	5,5	5,5	0,92	1,54	80	90	100	
49,33		56,8	851	5,5	5,5	0,92	1,35	80	90	100	
57,19		49,0	987	5,5	7,5	0,92	1,05	71	80	90	100
67,45		41,5	847	4	5,5	0,92	1,05	71	80	90	100
83,08		33,7	782	3	4,0	0,92	1,30			90	100
98,46		28,4	927	3	4,0	0,92	1,10		80	90	
111,41		25,1	769	2,2	3,0	0,92	1,33		80	90	
127,41		22,0	880	2,2	3,0	0,92	1,16		80	90	
147,69		19,0	1020	2,2	3,0	0,92	1,00	71	80	90	
174,20		16,1	820	1,5	2,0	0,92	1,24	71	80	90	
208,12		13,5	980	1,5	2,0	0,92	1,04	71	80		
233,85		12,0	807	1,1	1,5	0,92	1,26	71	80		
262,57		10,7	906	1,1	1,5	0,92	1,13	71	80		
306,66		9,1	722	0,75	1,0	0,92	1,10	71	80	90	
366,38		7,6	632	0,55	0,75	0,92	1,25	71	80		
411,67		6,8	710	0,55	0,75	0,92	1,11	71	80		
462,24	6,1	798	0,55	0,75	0,92	0,99	71	80			

32,17	1400	43,5	1126	5,58	7,4	0,92
38,13		36,7	1350	5,64	7,5	0,92
43,14		32,5	1350	4,99	6,6	0,92
49,33		28,4	1350	4,36	5,8	0,92
57,19		24,5	1220	3,40	4,5	0,92
67,45		20,8	1050	2,48	3,3	0,92
83,08		16,9	1200	2,30	3,1	0,92
98,46		14,2	1200	1,94	2,6	0,92
111,41		12,6	1200	1,72	2,3	0,92
127,41		11,0	1200	1,50	2,0	0,92
147,69		9,5	1200	1,29	1,7	0,92
174,20		8,0	1200	1,10	1,5	0,92
208,12		6,7	1200	0,92	1,2	0,92
233,85		6,0	1200	0,82	1,1	0,92
262,57		5,3	1200	0,73	1,0	0,92
306,67		4,6	930	0,48	0,6	0,92
366,38		3,8	930	0,40	0,5	0,92
411,67		3,4	930	0,36	0,5	0,92
462,24	3,0	930	0,32	0,4	0,92	

32,17	1400	43,5	808	4	5,5	0,92	1,39		90	100	
38,13		36,7	957	4	5,5	0,92	1,41	80	90	100	
43,14		32,5	1083	4	5,5	0,92	1,25	80	90	100	
49,33		28,4	1238	4	5,5	0,92	1,09	80	90	100	
57,19		24,5	1077	3	4,0	0,92	1,13	71	80	90	100
67,45		20,8	931	2,2	3,0	0,92	1,13	71	80	90	100
83,08		16,9	1147	2,2	3,0	0,92	1,05			90	100
98,46		14,2	927	1,5	2,0	0,92	1,29		80	90	
111,41		12,6	1049	1,5	2,0	0,92	1,14		80	90	
127,41		11,0	1199	1,5	2,0	0,92	1,00		80	90	
147,69		9,5	1020	1,1	1,5	0,92	1,18	71	80	90	
174,20		8,0	1203	1,1	1,5	0,92	1,00	71	80	90	
208,12		6,7	980	0,75	1,0	0,92	1,23	71	80		
233,85		6,0	1101	0,75	1,0	0,92	1,09	71	80		
262,57		5,3	1236	0,75	1,0	0,92	0,97	71	80		
306,67		4,6	712	0,37	0,5	0,92	1,31	71	80	90	
366,38		3,8	851	0,37	0,5	0,92	1,09	71	80		
411,67		3,4	956	0,37	0,5	0,92	0,97	71	80		
462,24	3,0	725	0,25	0,33	0,92	1,28	71	80			

32,17	900	28,0	1239	3,94	5,3	0,92
38,13		23,6	1485	3,99	5,3	0,92
43,14		20,9	1485	3,53	4,7	0,92
49,33		18,2	1485	3,08	4,1	0,92
57,19		15,7	1342	2,40	3,2	0,92
67,45		13,3	1155	1,75	2,3	0,92
83,08		10,8	1320	1,63	2,2	0,92
98,46		9,1	1320	1,37	1,8	0,92
111,41		8,1	1320	1,21	1,6	0,92
127,41		7,1	1320	1,06	1,4	0,92
147,69		6,1	1320	0,92	1,2	0,92
174,20		5,2	1320	0,78	1,0	0,92
208,12		4,3	1320	0,65	0,9	0,92
233,85		3,8	1320	0,58	0,8	0,92
262,57		3,4	1320	0,51	0,7	0,92
306,67		2,9	1023	0,34	0,5	0,92
366,38		2,5	1023	0,29	0,4	0,92
411,67		2,2	1023	0,25	0,3	0,92
462,24	1,9	1023	0,23	0,3	0,92	

32,17	900	28,0	691	2,2	3,0	0,92	1,79		90	100	
38,13		23,6	819	2,2	3,0	0,92	1,81	80	90	100	
43,14		20,9	927	2,2	3,0	0,92	1,60	80	90	100	
49,33		18,2	1059	2,2	3,0	0,92	1,40	80	90	100	
57,19		15,7	1228	2,2	3,0	0,92	1,09	71	80	90	100
67,45		13,3	988	1,5	2,0	0,92	1,17	71	80	90	100
83,08		10,8	1217	1,5	2,0	0,92	1,09			90	100
98,46		9,1	1057	1,1	1,5	0,92	1,25		80	90	
111,41		8,1	1196	1,1	1,5	0,92	1,10		80	90	
127,41		7,1	1368	1,1	1,5	0,92	0,96		80	90	
147,69		6,1	1081	0,75	1,0	0,92	1,22	71	80	90	
174,20		5,2	1275	0,75	1,0	0,92	1,03	71	80	90	
208,12		4,3	1117	0,55	0,75	0,92	1,18	71	80		
233,85		3,8	1256	0,55	0,75	0,92	1,05	71	80		
262,57		3,4	948	0,37	0,5	0,92	1,39	71	80		
306,67		2,9	748	0,25	0,33	0,92	1,37	71	80	90	
366,38		2,5	894	0,25	0,33	0,92	1,14	71	80		
411,67		2,2	1005	0,25	0,33	0,92	1,02	71	80		
462,24	1,9	812	0,18	0,25	0,92	1,26	71	80			

OT 125

PRESTAZIONI

PERFORMANCES

LEISTUNG

MOT 125

i	n ₁	n ₂	M ₂	KW ₁	HP ₁	R.D.
10.0	2800	280.0	1275	38.9	51.9	0.96
12.9		217.4	1277	30.3	40.4	0.96
15.7		178.5	1573	30.6	40.8	0.96
17.3		161.5	1737	30.6	40.8	0.96
22.3		125.4	1865	25.5	34.0	0.96
27.2		103.0	1615	18.1	24.2	0.96
34.0		82.3	1615	14.5	19.3	0.96
46.9		59.8	1445	9.4	12.6	0.96

i	n ₁	n ₂	M ₂	KW ₁	HP ₁	R.D.	fs	P.A.M.
10.0	2800	280.0	606	18.5	25	0.96	2.10	132 160
12.9		217.4	780	18.5	25	0.96	1.64	132 160
15.7		178.5	950	18.5	25	0.96	1.66	132 160
17.3		161.5	1050	18.5	25	0.96	1.65	132 160
22.3		125.4	1353	18.5	25	0.96	1.38	132 160
27.2		103.0	1647	18.5	25	0.96	0.98	132 160
34.0		82.3	1226	11	15	0.96	1.32	132
46.9		59.8	1412	9.2	12.5	0.96	1.02	132

10.0	1400	140.0	1500	22.9	30.5	0.96
12.9		108.7	1501	17.8	23.7	0.96
15.7		89.3	1850	18.0	24.0	0.96
17.3		80.8	2043	18.0	24.0	0.96
22.3		62.7	2194	15.0	20.0	0.96
27.2		51.5	1900	10.7	14.2	0.96
34.0		41.1	1901	8.5	11.4	0.96
46.9		29.9	1700	5.5	7.4	0.96

10.0	1400	140.0	982	15	20	0.96	1.53	132 160
12.9		108.7	1265	15	20	0.96	1.19	132 160
15.7		89.3	1541	15	20	0.96	1.20	132 160
17.3		80.8	1703	15	20	0.96	1.20	132 160
22.3		62.7	2194	15	20	0.96	1.00	132 160
27.2		51.5	1958	11	15	0.96	0.97	132 160
34.0		41.1	1672	7.5	10	0.96	1.14	132
46.9		29.9	1688	5.5	7.5	0.96	1.01	132

10.0	900	90.0	1650	16.2	21.6	0.96
12.9		69.9	1652	12.6	16.8	0.96
15.7		57.4	2035	12.7	17.0	0.96
17.3		51.9	2247	12.7	17.0	0.96
22.3		40.3	2413	10.6	14.1	0.96
27.2		33.1	2090	7.5	10.1	0.96
34.0		26.4	2090	6.0	8.0	0.96
46.9		19.2	1870	3.9	5.2	0.96

10.0	900	90.0	1121	11	15	0.96	1.47	132 160
12.9		69.9	1443	11	15	0.96	1.14	132 160
15.7		57.4	1757	11	15	0.96	1.16	132 160
17.3		51.9	1942	11	15	0.96	1.16	132 160
22.3		40.3	1706	7.5	10	0.96	1.41	132 160
27.2		33.1	2077	7.5	10	0.96	1.01	132 160
34.0		26.4	1907	5.5	7.50	0.96	1.10	132
46.9		19.2	1432	3	4.00	0.96	1.31	132

DIMENSIONI DI INGOMBRO

OVERALL DIMENSIONS

ALLGEMEINE ABMESSUNGEN

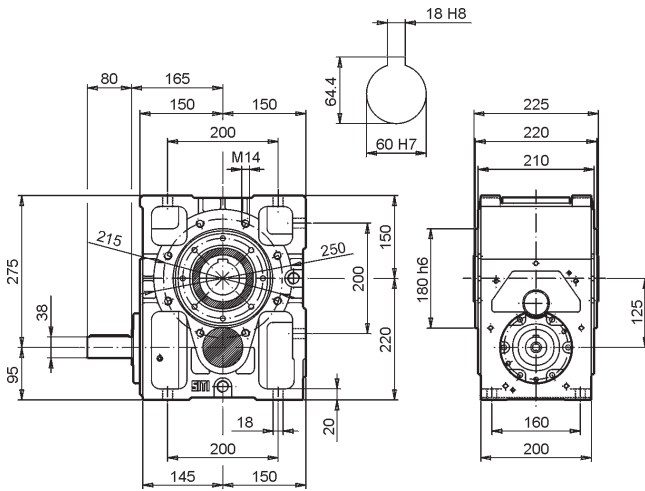

OT 125

= 82

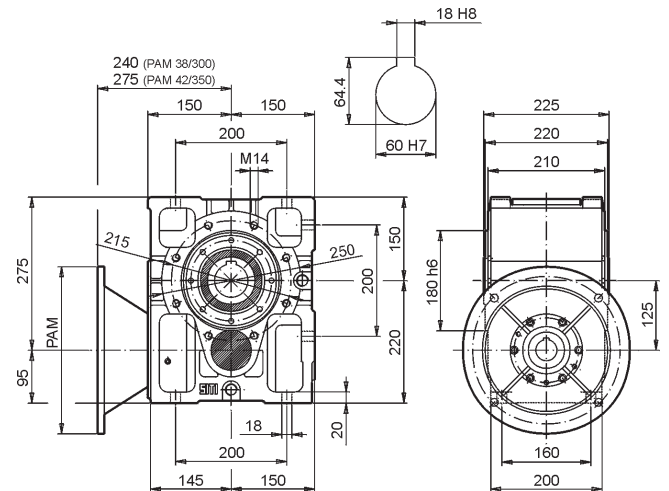

= 87

MOT 125

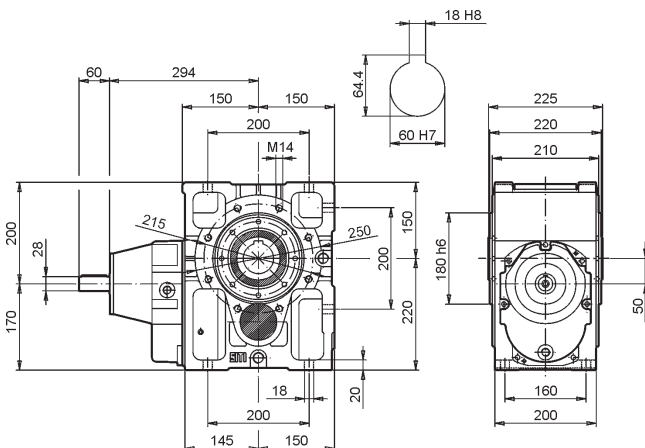

OT 125/3

= 95

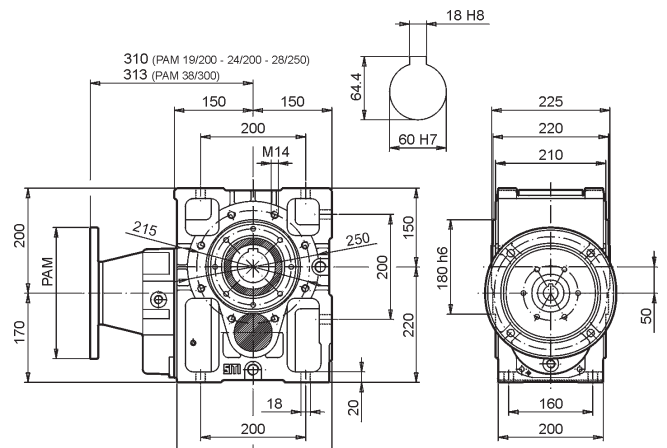

= 97

MOT 125/3

OT 160

PRESTAZIONI

PERFORMANCES

LEISTUNG

MOT 160

i	n ₁	n ₂	M ₂	KW ₁	HP ₁	R.D.
9.53	2800	293.7	2465	79.0	105.3	0.96
12.31		227.5	2805	69.6	92.8	0.96
15.00		186.7	3230	65.8	87.7	0.96
19.06		146.9	3230	51.8	69.0	0.96
24.62		113.8	3400	42.2	56.2	0.96
27.57		101.6	1700	18.8	25.1	0.96
30.00		93.3	3400	34.6	46.2	0.96
35.56		78.8	2210	19.0	25.3	0.96
38.33		73.0	3315	26.4	35.2	0.96
43.33		64.6	3060	21.6	28.8	0.96
55.37		50.6	3315	18.3	24.4	0.96

9.53	1400	146.9	2903	46.5	62.0	0.96
12.31		113.7	3297	40.9	54.5	0.96
15.00		93.3	3801	38.7	51.6	0.96
19.06		73.5	3794	30.4	40.5	0.96
24.62		56.9	3998	24.8	33.1	0.96
27.57		50.8	2004	11.1	14.8	0.96
30.00		46.7	4008	20.4	27.2	0.96
35.56		39.4	2608	11.2	14.9	0.96
38.33		36.5	3891	15.5	20.7	0.96
43.33		32.3	3604	12.7	16.9	0.96
55.37		25.3	3916	10.8	14.4	0.96

9.53	900	94.4	3190	32.8	43.8	0.96
12.31		73.1	3630	29.0	38.6	0.96
15.00		60.0	4180	27.4	36.5	0.96
19.06		47.2	4180	21.5	28.7	0.96
24.62		36.6	4400	17.5	23.4	0.96
27.57		32.6	2200	7.8	10.4	0.96
30.00		30.0	4400	14.4	19.2	0.96
35.56		25.3	2860	7.9	10.5	0.96
38.33		23.5	4290	11.0	14.6	0.96
43.33		20.8	3960	9.0	12.0	0.96
55.37		16.3	4290	7.6	10.1	0.96

i	n ₁	n ₂	M ₂	KW ₁	HP ₁	R.D.	fs	P.A.M.
9.53	2800	293.7	687	22	30	0.96	3.59	160 180
12.31		227.5	887	22	30	0.96	3.16	160 180
15.00		186.7	1081	22	30	0.96	2.99	160 180
19.06		146.9	1373	22	30	0.96	2.35	160 180
24.62		113.8	1773	22	30	0.96	1.92	160 180
27.57		101.6	993	11	15	0.96	1.71	160 180
30.00		93.3	2161	22	30	0.96	1.57	160 180
35.56		78.8	1281	11	15	0.96	1.73	160
38.33		73.0	2761	22	30	0.96	1.20	160 180
43.33		64.6	1561	11	15	0.96	1.96	160
55.37		50.6	1994	11	15	0.96	1.66	160

9.53	1400	146.9	1373	22	30	0.96	2.11	160 180
12.31		113.7	1773	22	30	0.96	1.86	160 180
15.00		93.3	2161	22	30	0.96	1.76	160 180
19.06		73.5	2746	22	30	0.96	1.38	160 180
24.62		56.9	3546	22	30	0.96	1.13	160 180
27.57		50.8	1986	11	15	0.96	1.01	160 180
30.00		46.7	3634	18.5	25	0.96	1.10	160 180
35.56		39.4	2561	11	15	0.96	1.02	160
38.33		36.5	3765	15	20	0.96	1.03	160 180
43.33		32.3	3121	11	15	0.96	1.15	160
55.37		25.3	3988	11	15	0.96	0.98	160

9.53	900	94.4	1457	15	20	0.96	2.19	160 180
12.31		73.1	1881	15	20	0.96	1.93	160 180
15.00		60.0	2292	15	20	0.96	1.82	160 180
19.06		47.2	2912	15	20	0.96	1.44	160 180
24.62		36.6	3761	15	20	0.96	1.17	160 180
27.57		32.6	1545	5.5	7.5	0.96	1.42	160 180
30.00		30.0	4584	15	20	0.96	0.96	160 180
35.56		25.3	1992	5.5	7.5	0.96	1.44	160
38.33		23.5	4295	11	15	0.96	1.00	160 180
43.33		20.8	2428	5.5	7.5	0.96	1.63	160
55.37		16.3	3102	5.5	7.5	0.96	1.38	160

DIMENSIONI DI INGOMBRO

OVERALL DIMENSIONS

ALLGEMEINE ABMESSUNGEN

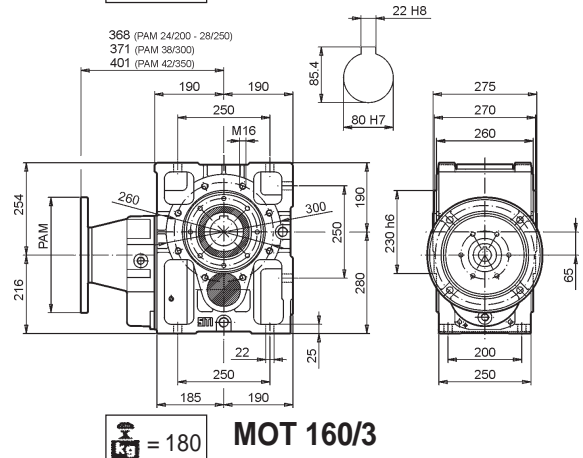
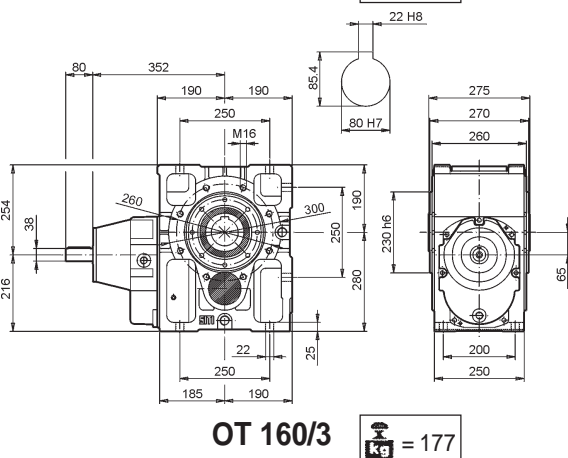
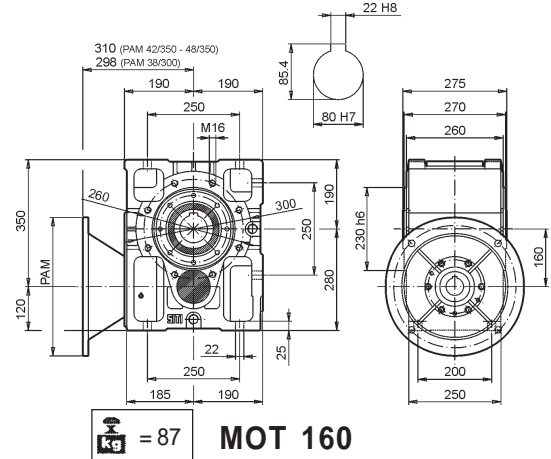
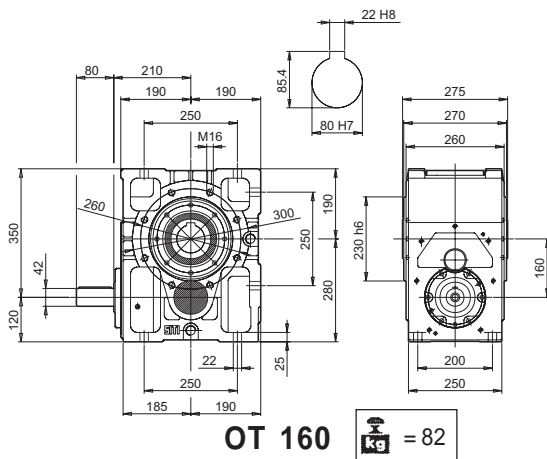

CARICHI RADIALI DELLE GRANDEZZE:
80 - 100 - 125 - 160

SIZE OVERHUNG LOADS:
80 - 100 - 125 - 160

RADIALE BELASTUNGEN DER
GRÖSSEN:
80 - 100 - 125 - 160

ALBERO VELOCE/INPUT SHAFT/EINGANGSWELLE		
1400 min ⁻¹	OT 80	OT 80/3
		800

ALBERO LENTO/OUTPUT SHAFT/ABTRIEBSWELLE							
OT 80 - OT 80/3							
min ⁻¹	0°	30°	60°	90°	120°	150°	180°
20	8296	8576	9307	10429	11718	12726	13123
40	6424	6715	7404	8553	9875	10964	11370
60	4942	5149	5774	6814	8010	8997	9413
80	4486	4702	5350	6431	7675	8755	9133
100	4053	4270	4862	5940	7185	8251	8300
120	3727	3891	4538	5567	6864	7944	8376
140	3026	3159	3685	4520	5573	6450	6801
160	4052	4230	4934	6052	7462	8636	9106

Rotazione oraria
Clockwise rotation
Uhrzeigersinn

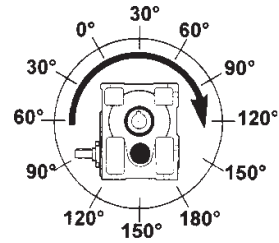

Rotazione antioraria
Anticlockwise rotation
Gegenuhrzeigersinn

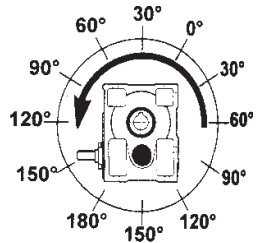

ALBERO VELOCE/INPUT SHAFT/EINGANGSWELLE		
1400 min ⁻¹	OT 100	OT 100/3
		1200

ALBERO LENTO/OUTPUT SHAFT/ABTRIEBSWELLE							
OT 100 - OT 100/3							
min ⁻¹	0°	30°	60°	90°	120°	150°	180°
20	13186	13632	14793	16577	18625	20227	20859
40	9972	10422	11491	13274	15327	17017	17646
60	6858	7146	8013	9456	11117	12486	13064
80	6805	7134	8116	9758	11644	13283	13855
100	6684	7041	8019	9795	11848	13607	14347
120	6147	6417	7485	9180	11319	13100	13813
140	5704	5945	6945	8518	10502	12155	12817
160	5346	5580	6509	7984	9844	11393	12013

ALBERO VELOCE/INPUT SHAFT/EINGANGSWELLE		
1400 min ⁻¹	OT 125	OT 125/3
		1900

ALBERO LENTO/OUTPUT SHAFT/ABTRIEBSWELLE							
OT 125 - OT 125/3							
min ⁻¹	0°	30°	60°	90°	120°	150°	180°
20	15823	16358	17752	19892	22350	24273	25031
40	12393	12953	14281	16498	19050	21150	21934
60	9556	9957	11165	13176	15490	17397	18202
80	9510	9970	11344	13637	16273	18563	19364
100	9548	10059	11456	13993	16926	19439	20496
120	8782	9167	10693	13115	16170	18715	19733
140	8148	8505	9921	12168	15003	17364	18309
160	7637	7972	8299	11405	14063	16275	17161

ALBERO VELOCE/INPUT SHAFT/EINGANGSWELLE		
1400 min ⁻¹	OT 160	OT 160/3
		2800

ALBERO LENTO/OUTPUT SHAFT/ABTRIEBSWELLE							
OT 160 - OT 160/3							
min ⁻¹	0°	30°	60°	90°	120°	150°	180°
20	24488	25316	27473	30785	34589	37565	38739
40	16891	17654	19464	22485	25962	28825	29892
60	15552	16205	18171	21443	25209	28314	29624
80	12982	13610	15484	18460	22214	25340	26432
100	12549	13220	15056	18391	22246	25548	26938
120	11541	12047	14053	17236	21252	24596	25935
140	11640	12150	14173	17383	21434	24806	26156
160	10910	11388	13284	16293	20089	23251	24516

ACCESSORI
ACCESSORIES
 ZUBEHÖR

	Pag. Page <i>Seite</i>
FLANGIA IN USCITA OUTPUT FLANGES <i>ABTRIEBSFLANSCH</i>	54
ALBERI LENTI OUTPUT SHAFTS <i>STECKENWELLEN</i>	55
ALBERO VELOCE BISPORGENTE "OT" DOUBLE EXTENDED INPUT SHAFT "OT" <i>WELLENENDEN IM EINGANG (OT BAUREIHE)</i>	55
BRACCI DI REAZIONE TORQUE ARMS <i>DREHMOMENTSTÜTZEN</i>	56
BRACCI DI REAZIONE PER RIDUTTORI PENDOLARI TORQUE ARMS FOR SHAFT MOUNTED <i>DREHMOMENTSTÜTZEN FÜR FLACHGETRIEBE</i>	56
DISPOSITIVO ANTIRETRO BACKSTOP DEVICE <i>RUCKLAUFSPERRE</i>	57
ALBERO LENTO CAVO CON CALETTATORE OUTPUT HOLLOW SHAFT WITH COUPLER <i>ABTRIEBSHOHLWELLE MIT KUPPLER</i>	58

FLANGE IN USCITA

Tutti i riduttori delle serie OT, PL, PD possono essere equipaggiati, su richiesta, con flange in uscita di dimensioni unificate (flange B5). Si è optato per la forma quadrata sulle grandezze 63 - 80 - 100 e per la forma circolare sulle grandezze 125 e 160. Si assume come standard la posizione destra guardando il riduttore dal lato dell'entrata nella posizione di montaggio B3. Anche sulla grandezza OT 56 è di forma circolare.

OUTPUT FLANGES

All OT, PL and PD gearboxes can be equipped, upon request, with output B5 flanges. Square flanges have been provided on sizes 63 - 80 - 100 and round flanges are available on sizes 125 - 160. Standard position is on the right looking at the gearbox from input side in mounting position B3. Even on the size OT 56, it is round.

ABTRIEBSFLANSCH

Auf Anfrage können alle OT - PL - PD Getriebe mit einem genormten Abtriebsflansch (B5) geliefert werden. Für die Getriebe 63 - 80 und 100 sind rechteckige, für die Getriebe 125 und 160 sind runde Flansche vorgesehen. In der Standardausführung liegt der Flansch bei der Einbaulage B3 (Eingangswelle unten, Abtriebswelle oben) auf die Eingangswelle gesehen rechts. Auch auf der Größe OT 56 ist der Abtriebsflansch rund.

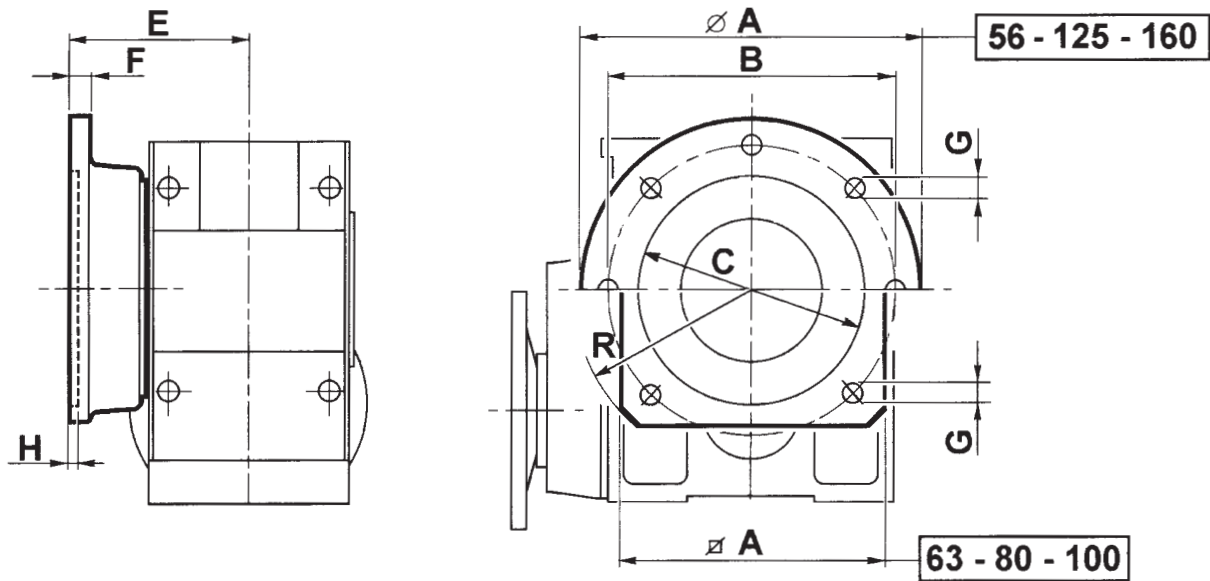

	○ A	□ A	B	C	E	F	G	H	R
56	160	-	130	110	80	11	4x11	5	-
63	-	150	165	130	113	12	4x11	5	100
80	-	190	215	180	132.5	14	4x14	6	125
100	-	240	265	230	150.5	16	4x16	5	150
125	350	-	300	250	174	18	8x16	6	-
160	450	-	400	350	195	20	8x18	7	-

ALBERI LENTI

Tutti i riduttori delle serie OT e PL possono essere equipaggiati, su richiesta, con alberi lenti semplici o con alberi lenti doppi.

Per l'albero lento semplice è realizzata la versione con spallamento, mentre sul lato opposto all'uscita della parte sporgente, il canotto è chiuso da apposita rondella.

L'albero lento doppio è invece realizzato, per semplicità costruttiva, con unico diametro, restando la funzione di spallamento affidata all'organo utilizzatore che sarà fissato alle estremità libere dell'albero.

OUTPUT SHAFTS

All OT and PL gearboxes can be equipped, on request, with single or double output shafts.

The single output shaft is accomplished in the version with shoulder, while on the opposite side the hollow shaft is closed by a suitable washer.

The double output shaft is, on the contrary, accomplished with a single diameter, for ease of manufacture. The function of shouldering is developed by the connection piece which will be placed on the free shaft ends.

STECKWELLEN

Alle OT und PL Getriebe können, auf Anfrage, mit einseitiger oder doppelseitiger Steckwelle ausgerüstet werden.

Die einseitige Ausführung ist mit einer Schulter ausgeführt, und die Hohlwelle ist bei einer Scheibe auf der gegenüberliegenden Seite geschlossen.

Die doppelseitige Steckwelle ist, für eine einfacheren Bau, mit einzeitigem Durchmesser ausgeführt, und die Schulterfunktion ist direkt von dem zusammenpassenden Maschinenteil entwickelt.

Albero lento semplice
Single output shaft
Einseitige Steckwelle

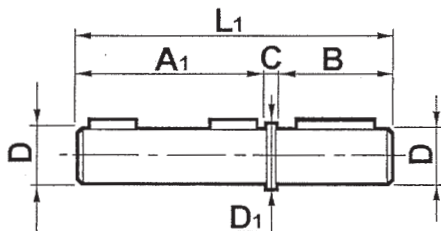

	D	B	D1	A1	C	L1
56	25	50	30	115	5	170
63	30	60	35	125	5	190
80	35	60	40	150	5	215
100	45	90	50	170	8	268
125	60	110	70	210	10	330
160	80	140	90	255	15	410

Albero lento doppio
Double output shaft
Doppelseitige Steckwelle

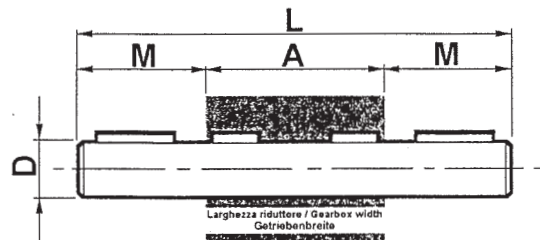

	D	A	L	M
56	25	120	220	50
63	30	135	255	60
80	35	160	280	60
100	45	180	360	90
125	60	225	445	110
160	80	275	555	140

ALBERO VELOCE BISPORGENTE OT

Su richiesta, gli OT possono essere forniti con albero veloce bisporgente.

La seconda sporgenza è realizzata con un secondo pignone conico posto sul lato opposto all'entrata che accoppia con la stessa corona conica.

Questa soluzione potrà essere adottata anche per i riduttori con precoppia.

In caso di esigenze particolari, sarà possibile provvedere la seconda sporgenza sull'albero intermedio parallelo all'asse di uscita.

DOUBLE EXTENDED INPUT SHAFT OT

Upon request, OT gearboxes can be supplied with double extended input shaft.

Second extension is achieved with a second bevel pinion on the opposite side of the input mating with the bevel gear.

Same solution can be adopted also for gearboxes with primary reduction.

When necessary, a second extension on the intermediate shaft parallel to the output axis could be provided.

WELLENENDEN IM EINGANG ("OT" BAUREIHE)

Auf Anfrage können die OT - Kegelstirnradgetriebe mit einem zweiten normalen Wellenende ausgeführt werden.

Das zweite Wellenende ist im Getriebeinnern als Kegelritzel ausgebildet und greift in den Kegelradteller ein.

Dies gilt ebenfalls für die Vorstufengetriebe.

In Sonderfällen kann das zweite Wellenende auch aus der mittleren Stufe, also parallel zu der Abtriebswelle, herausgeführt werden.

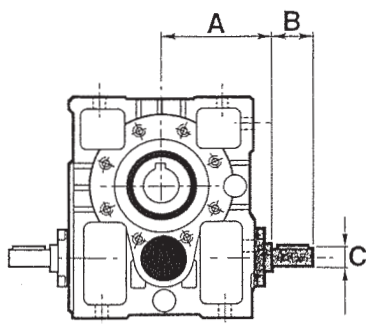

	A	B	C
OT 56	83	40	19
OT 63	95	40	19
OT 80	115	50	24
OT 100	140	60	28
OT 125	165	80	38
OT 160	210	110	42

BRACCI DI REAZIONE

I riduttori della serie OT possono essere anche equipaggiati, come accessorio, con braccio di reazione per montaggio pendolare.

I bracci di reazione della SITI consentono di poter essere applicati sia sulla superficie normale di appoggio del riduttore nel montaggio B3, sia sul lato superiore o sulla superficie laterale opposta al lato di entrata, in virtù della dimensioni di foratura esattamente uguali su tutte queste facce.

Possono inoltre essere posti o nella posizione mostrata sulla figura, o nella posizione simmetricamente speculare ad essa rispetto all'asse verticale di figura.

Essi sono stati dimensionati per poter resistere, con elevati margini di sicurezza, a tutti i massimi carichi che possono essere applicati sull'uscita, così come ai massimi pesi dei riduttori montati con motore.

TORQUE ARMS

Every gearbox of the OT line can be equipped with a torque arm, an optional item needed to mount the gearbox in a swinging position.

SITI torque arms can be applied on any side of OT gearboxes (upper, lower, etc.) thanks to the fact that all sides are identically drilled.

Moreover, torque arms can be mounted both according to the position shown in the sketch or the symmetrical one with respect to the vertical axis of figure.

All torque arms have been sized to bear heaviest loads on the output shaft as well as the biggest weights of all applicable motors.

DREHMOMENTSTUTZEN

Die OT - Getriebe können mit dazugehöriger Drehmomentstütze in Aufsteckausführung montiert werden.

Die Drehmomentstütze ist auch als Zubehör lieferbar.

Sie kann an jeder bearbeiteten Getriebeseite, die der Befestigung des Getriebes dient, montiert werden.

Die Drehmomentstützen können sowohl wie in der Abbildung dargestellt, als auch spiegelbildlich, angebracht werden.

Sie sind so konzipiert, daß sie mit hoher Sicherheit die maximale Belastung im Ausgang des Getriebes und das höchste Gewicht des Getriebes bzw. des Getriebemotors aushalten können.

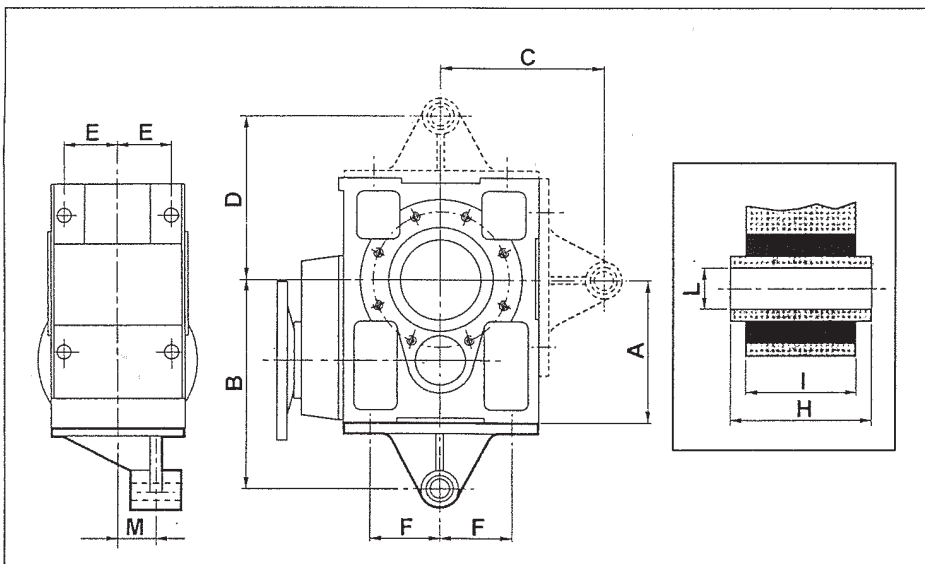

	63	80	100	125	160
A	120	155	180	220	280
B	168	219	257	308	415
C	128	164	202	238	325
D	128	164	202	238	325
E	46	55	65	80	100
F	50	67.5	85	100	125
H	60	60	80	100	100
I	52	52	70	90	90
L	15	18	22	25	30
M	31.5	44	45	55	80

BRACCI DI REAZIONE PER RIDUTTORI PENDOLARI

TORQUE ARMS FOR SHAFT MOUNTED

DREHMOMENTSTÜTZEN FÜR FLACHGETRIEBE

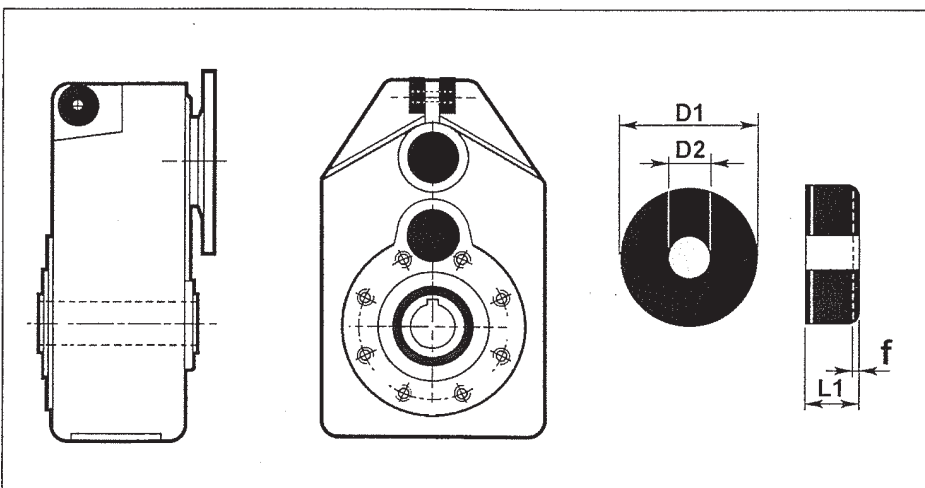

	63	80	100	125	160
D1	30	40	40	60	80
L1	15	20	20	30	40
D2	11	12.5	12.5	21	25
f _{min}	-	1.5	1.5	3	3.7
f _{max}	-	2.3	2.3	4	6

DISPOSITIVO ANTIRETRO

A richiesta, è possibile fornire i riduttori OT provvisti di dispositivo antiretro, per evitare il moto retrogrado, ovvero il fatto che il riduttore possa essere azionato attraverso l'albero lento dal carico resistente divenuto carico motore.

L'antiretro è provvisto per l'installazione sulla seconda sporgenza dell'albero veloce, a valle dei due cuscinetti conici, come appare dalla figura in sezione.

I cuscinetti antiretro sono stati ampiamente dimensionati in funzione della massima coppia permessa da ogni riduttore, e pertanto ne è consentito l'impiego con qualsiasi rapporto di riduzione, anche particolarmente veloce.

Dovrà essere sempre precisato in fase d'ordine per quale senso di rotazione deve essere consentita la rotazione libera.

BACKSTOP DEVICE

On request it is possible to have backstop mounted on the OT line. Purpose of the backstop is to prevent the reversible motion, that is the fact that the gearbox might be operated through the output shaft by the resisting load so becoming driving load.

The backstop device is located on the input shaft downstream the two taper roller bearings as we can see from the sketch enclosed.

The irreversible bearing have been largely oversized according to the maximum torque allowed by each gearbox so that backstop devices are suitable for any reduction ratio.

The direction of free rotation must be specified when the order is placed.

RÜCKLAUFSPERRE

Die Rücklaufsperrre ist eine Einrichtung im Getriebe, um die Anlage nach dem Abschalten des Motors am Rückwärtslauf zu hindern.

Wie in dem Ausschnitt ersichtlich, ist die Anbringung der Rücklaufsperrre an der gegenüberliegenden Seite der Eingangswelle vorgesehen.

Die Rücklaufsperrre ist ausreichend dimensioniert und kann an jedem Getriebe sowohl mit hohen als auch mit niedrigen Untersetzungen angebaue werden.

Bei Bestellung muß der Drehsinn stets angegeben werden.

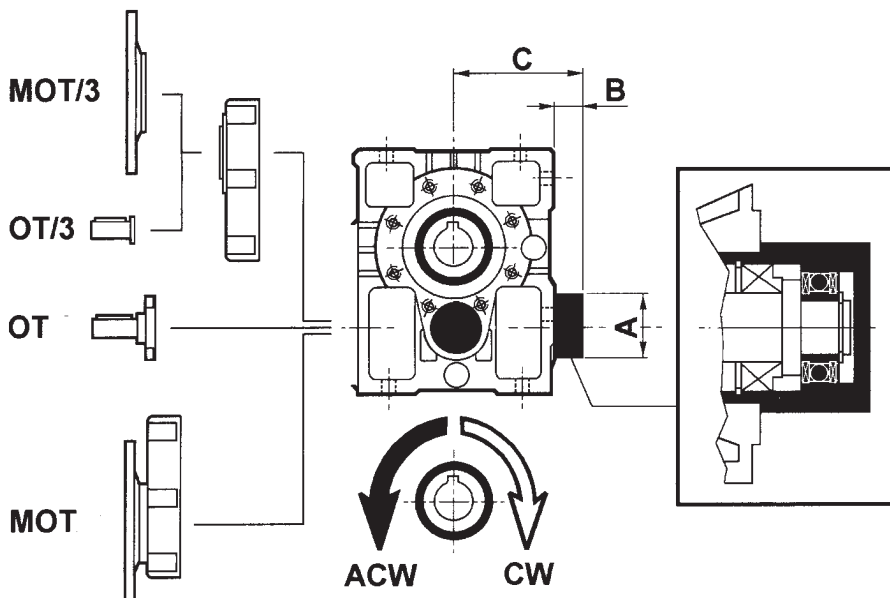

	A	B	C
63	62	39.6	119.6
80	72	41	141
100	78	42	167
125	74.9	49.6	199.6
160	74.9	54.6	244.6

Anche sui riduttori PL e PD il dispositivo antiretro può essere applicato sulla seconda sporgenza dell'albero veloce.

Even on PL and PD, the backstop device might be fitted on the second end of the input shaft.

Auch auf PL und PD, kann die Rücklaufsperrre auf der gegenüberliegenden Seite der Eingangswelle vorgesehen sein.

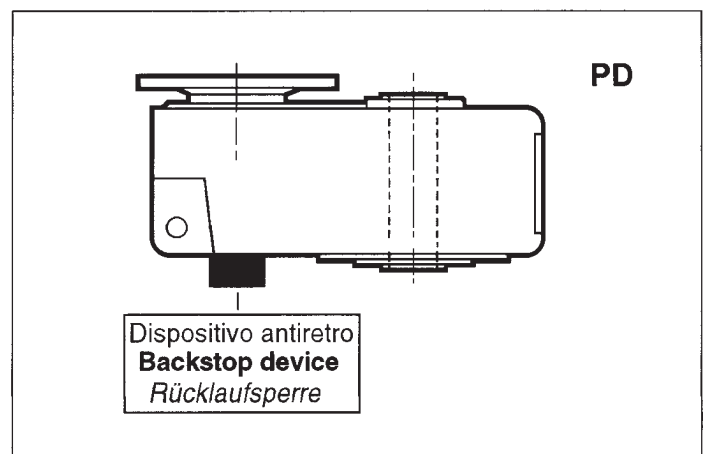
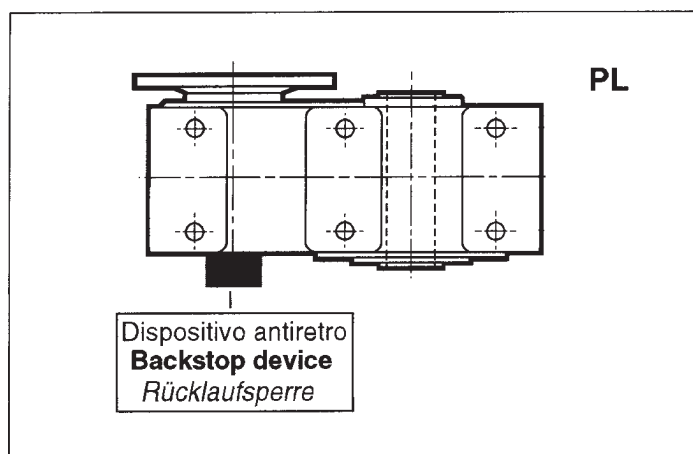

ALBERO LENTO CAVO CON CALETTATORE

OUTPUT HOLLOW SHAFT WITH COUPLER

ABTRIEBSHOHLWELLE MIT KUPPLER

Dimensionamento e tolleranze alberi lenti cavi con calettatore su riduttori serie OT/2 e OT3.

Dimensions and tolerances of input hollow shafts with coupler for gearboxes of the OT/2 and OT3 series.

Bemessung und Toleranzen der Abtriebshohlwellen mit Kuppler an Untersetzungsgetrieben der Serie OT/2 und OT3.

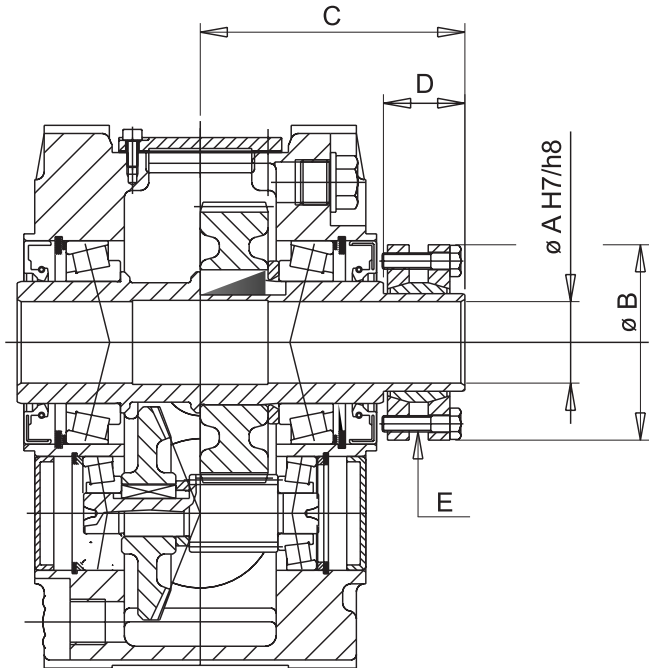

	Ø A	Ø B	C	D	E	Ts Nm
OT 56	25	60	88	28	M 5	4
OT 63	30	72	98	30	M 6	12
OT 80	35	80	112	32	M 6	12
OT 100	45	100	127	37	M 6	12
OT 125	60	115	151	38	M 6	12
OT 160	80	170	188	53	M 8	30

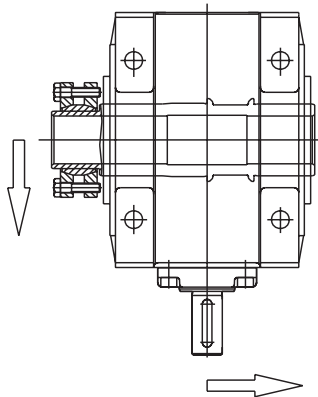

STANDARD - **STANDARD** - STANDARD

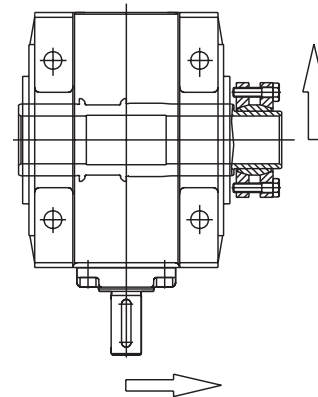

A RICHIESTA - **ON REQUEST** - AUF WUNSCH

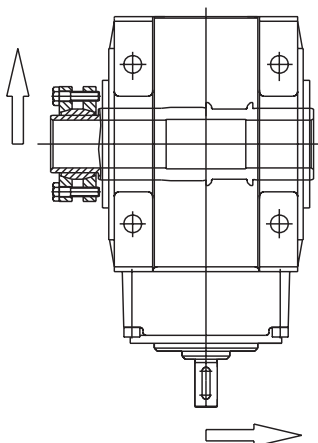

STANDARD - **STANDARD** - STANDARD

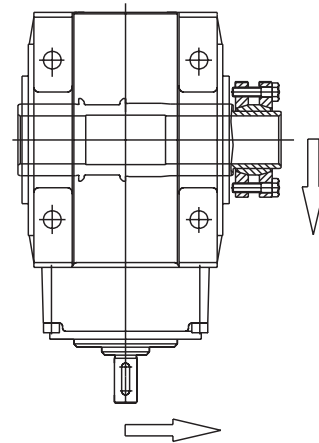

A RICHIESTA - **ON REQUEST** - AUF WUNSCH