

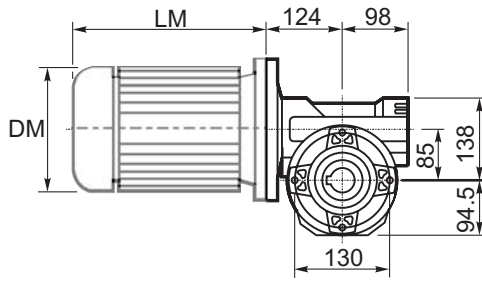

M... \FB

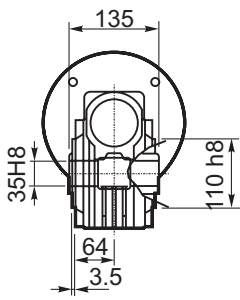

4 отверстия M10x18
4 holes M10x18

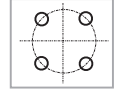

	D1	W1	X
Тип В Type B	ø25h6	28	M8
Тип S Type S	ø24h6	27	M8

M... \PA

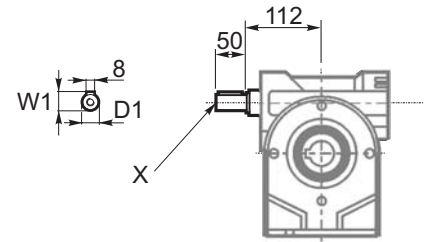
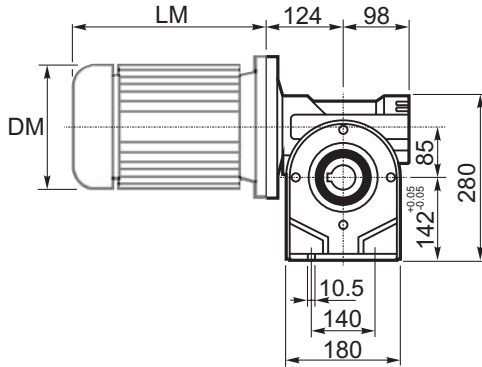
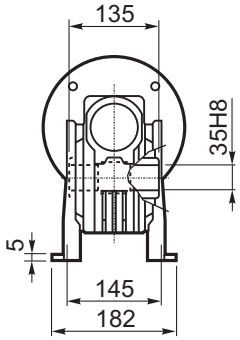

R...

**ВЫХОДНОЙ
ВАЛ
OUTPUT
SHAFT**

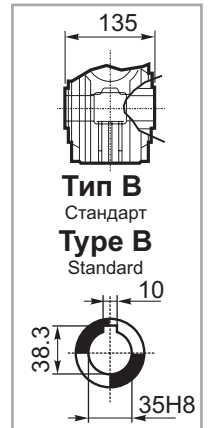

M... \PB

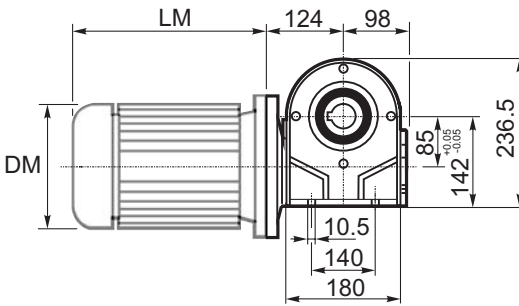
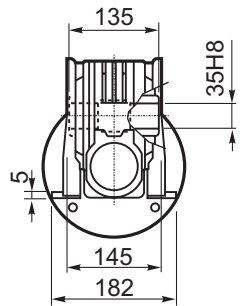

M... \PV

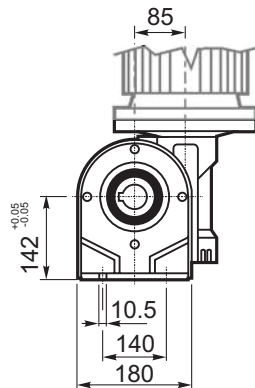
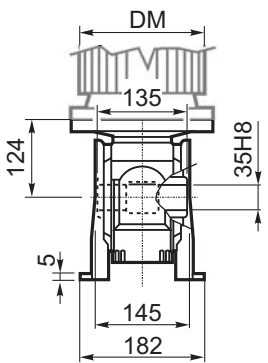

**ЛАПЫ
Тип S**
По запросу
**FEET
Type S**
On request

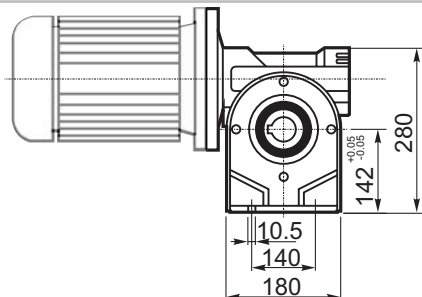
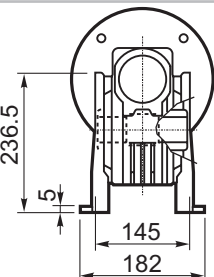



M... \FC

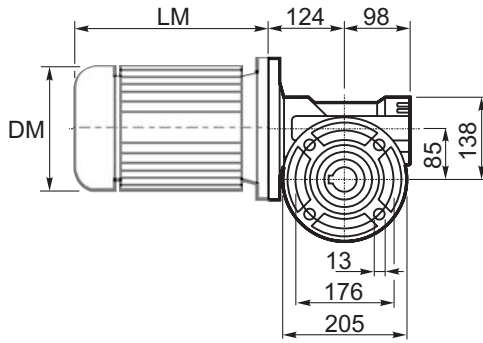
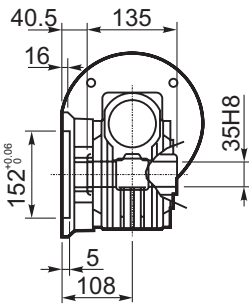

M... \FL

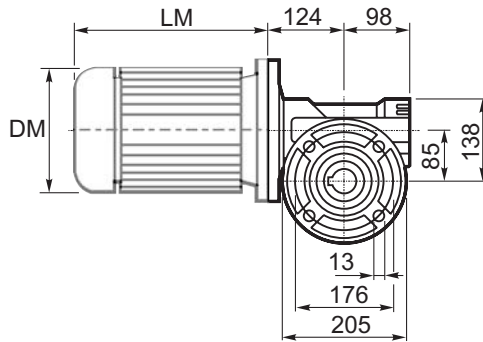
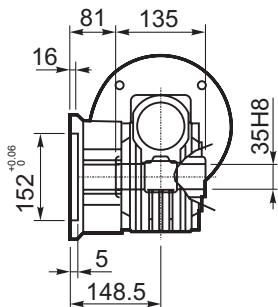

M... \F1

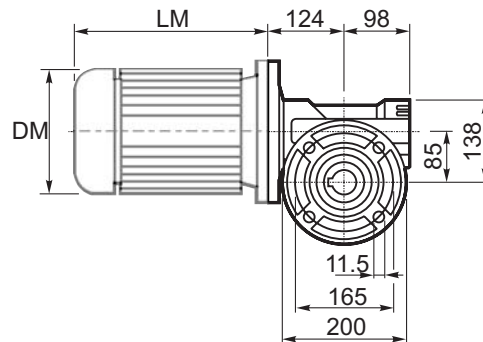
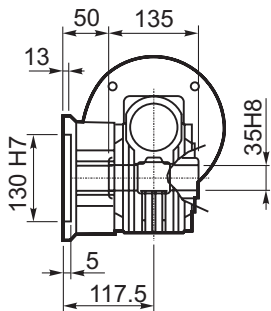

M... \F2

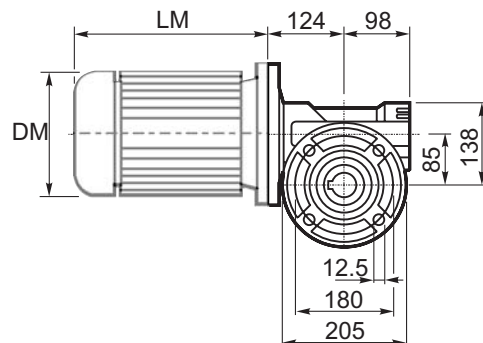
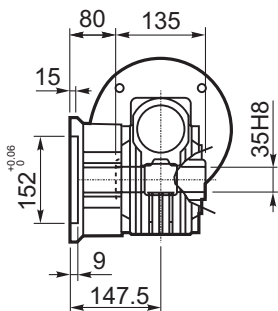

M... \F4

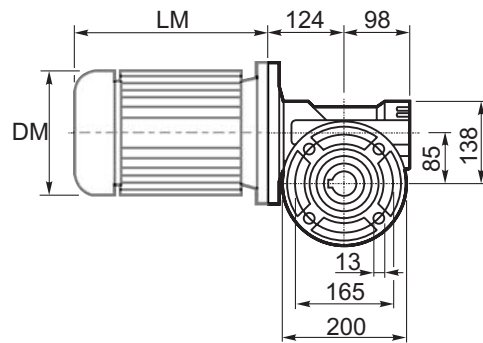
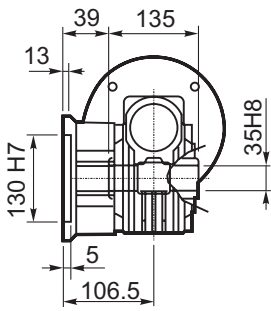

	D1	W1	X
Тип B Type B	ø25h6	28	M8
Тип S Type S	ø24h6	27	M8

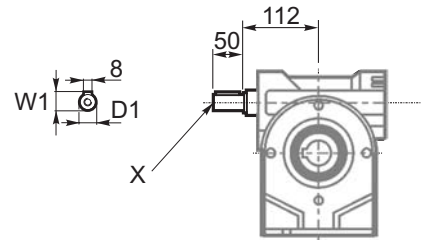

R...

**ВЫХОДНОЙ
ВАЛ
OUTPUT
SHAFT**

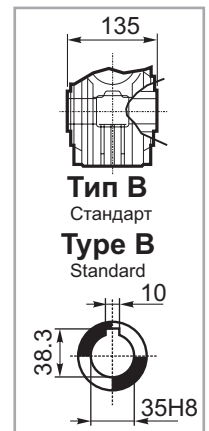

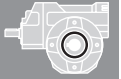

M... \FB

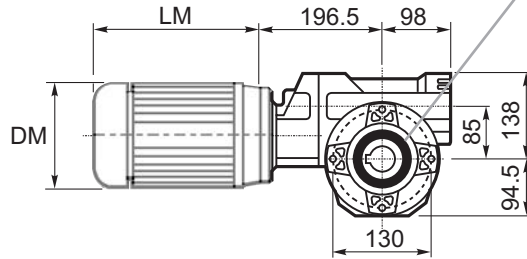
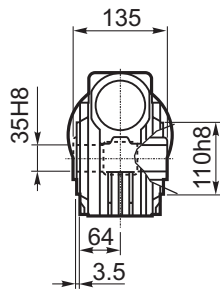

4 отверстия M10x18
4 holes M10x18

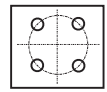

M... \PA

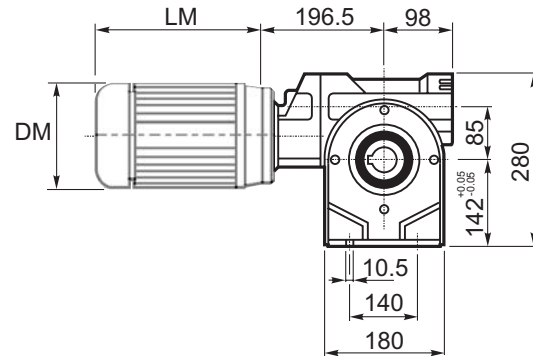
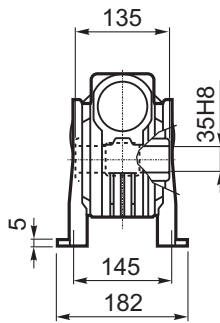

R...

**ВЫХОДНОЙ
ВАЛ
OUTPUT
SHAFT**

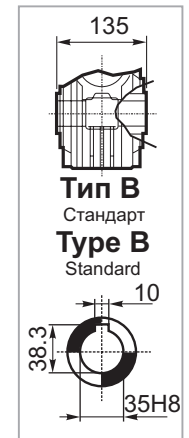
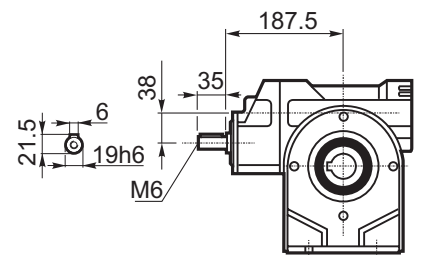

M... \PB

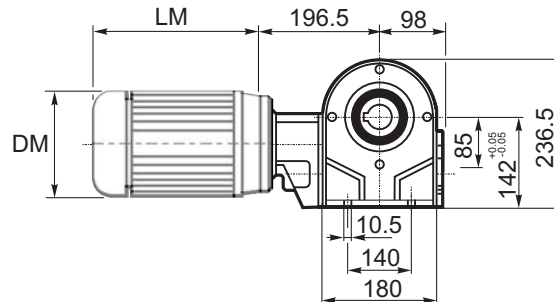
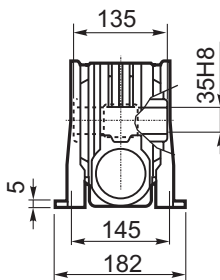

M... \PV

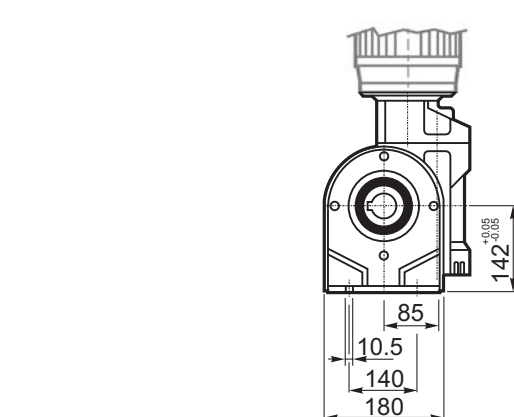
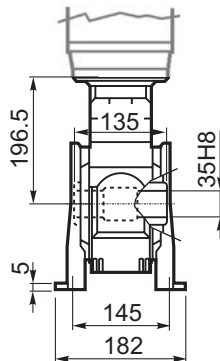

**ЛАПЫ
Тип S**

По запросу

**FEET
Type S**

On request

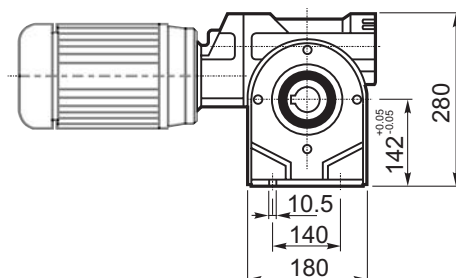
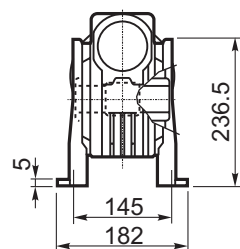



M... \FC

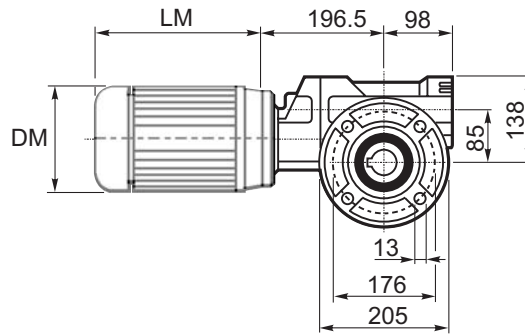
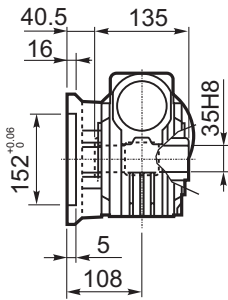

M... \FL

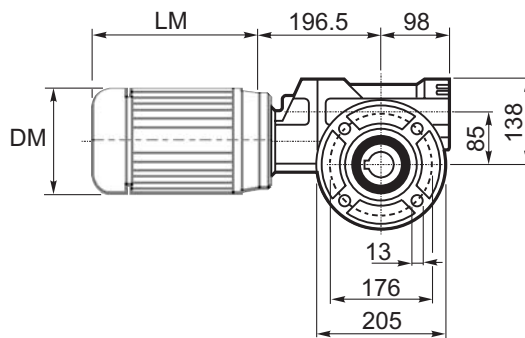
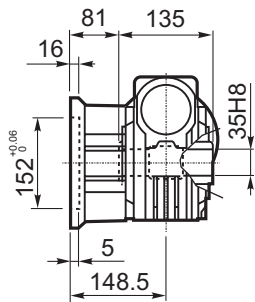

R...

**ВЫХОДНОЙ
ВАЛ
OUTPUT
SHAFT**

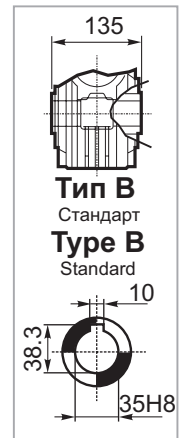
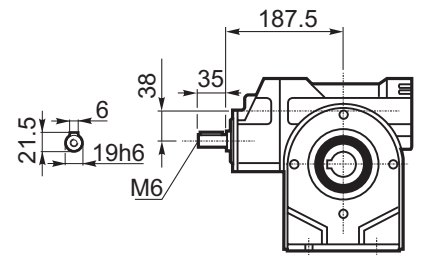

M... \F1

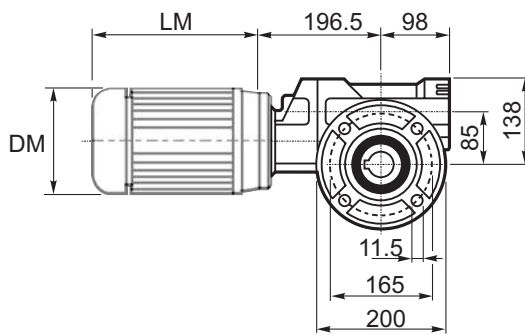
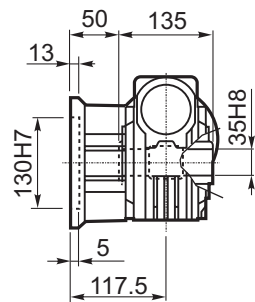

M... \F2

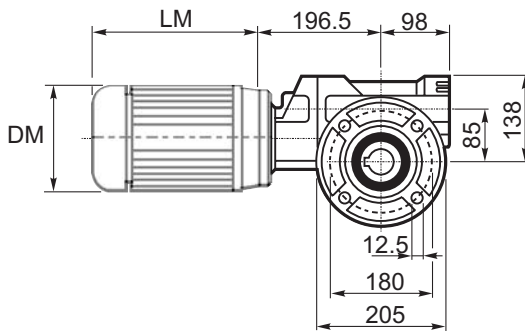
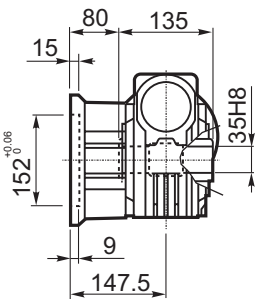

M... \F4

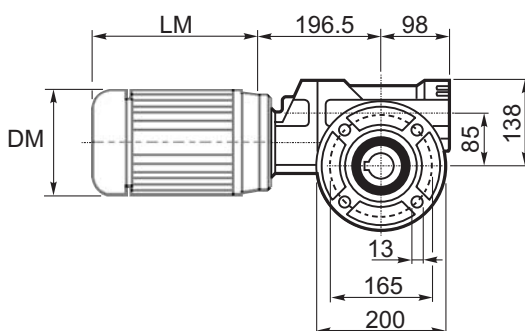
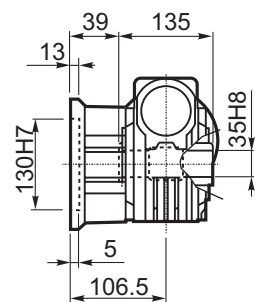

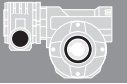

M... \FB

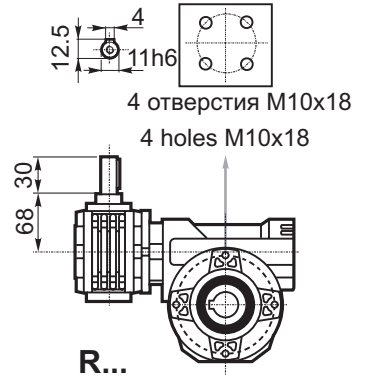
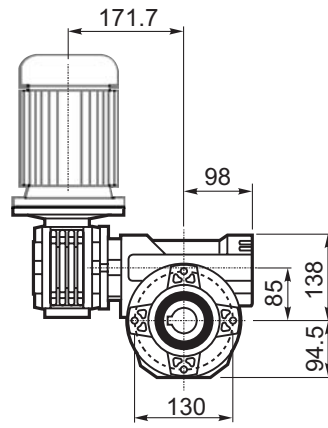
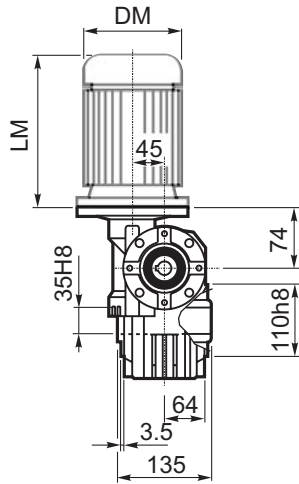

M... \PA

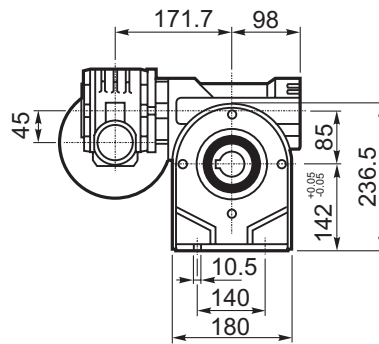
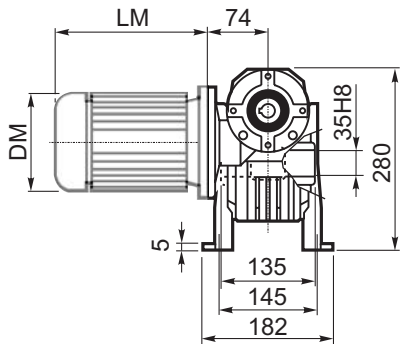

ВЫХОДНОЙ
ВАЛ
OUTPUT
SHAFT

ЛАПЫ
Тип S
По запросу

FEET
Type S
On request

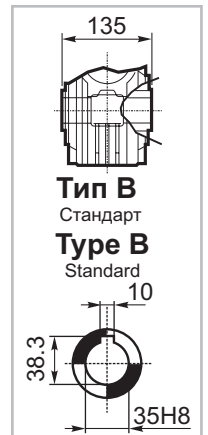
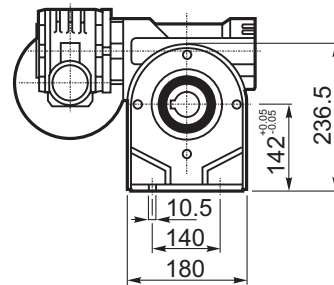
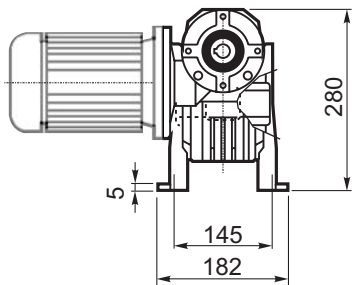

M... \FC

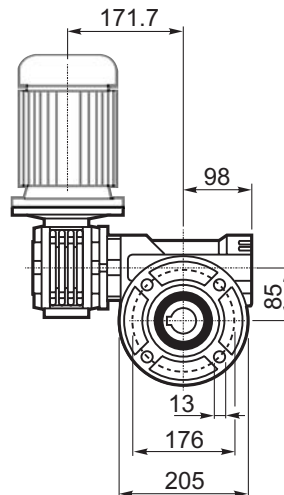
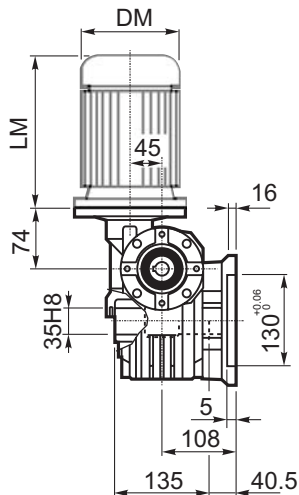

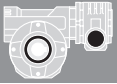

M... \FL

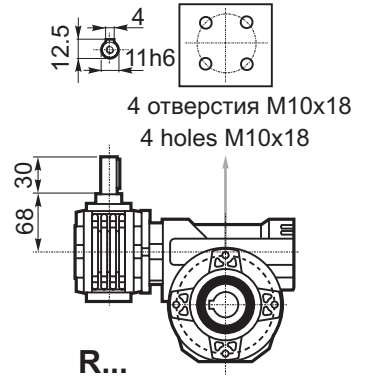
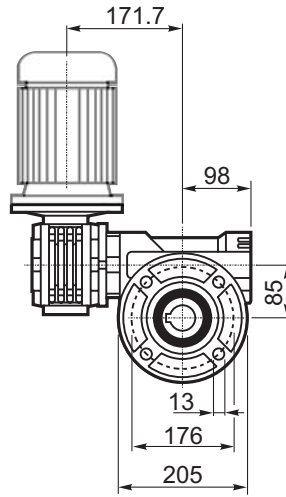
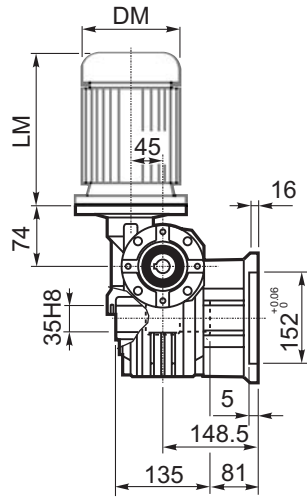

M... \F1

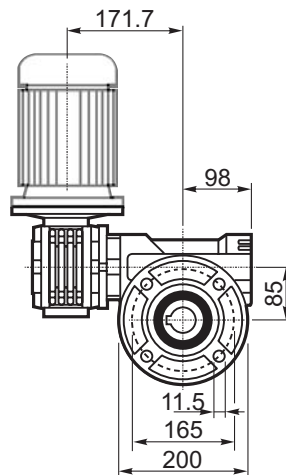
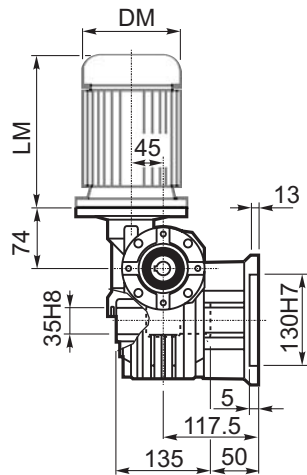

ВЫХОДНОЙ
ВАЛ
OUTPUT
SHAFT

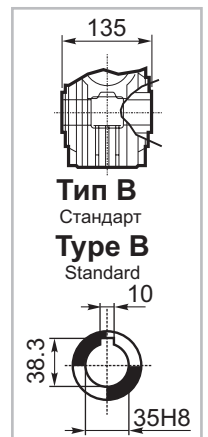

M... \F2

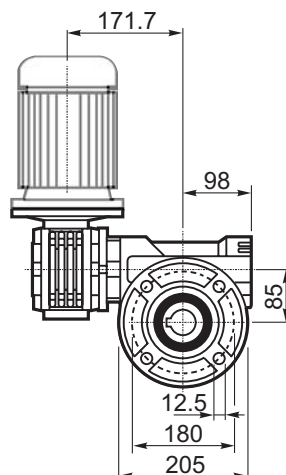
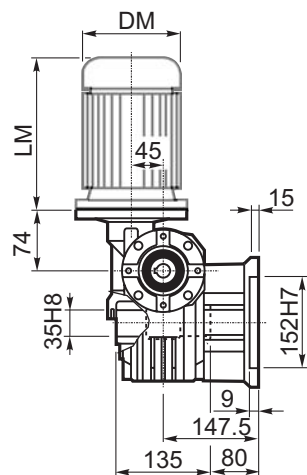

M... \F4

