



SERIES GFA



GFA COUPLING with Steel Sleeve



PRESENTATION

The "GIFLEX®" GFA range of flexible couplings represent couplings designed with a compact structure for industrial applications, torsionally rigid and capable of compensating angular, parallel and combined misalignments.

The special configuration with the single-piece sleeve and the seals at the two ends renders the couplings suitable for use in aggressive environments and in particularly demanding operating conditions. The performance complies with the characteristics of a dual articulation, constant-velocity coupling intended to be used both for general and specific applications and with the possibility of also being mounted on shafts with a large free gap.

The operating limits defined by the maximum torque, by the rotating speed and the permitted angular misalignment are the result of a design based on a targeted choice of materials, the heat treatment and the toothing geometry.

The reliability of the stated operating limits has been confirmed by testing the fatigue limits both at the surface pressure (Hertzian pressure) and at bending and to destructive wear in accordance with calculation schemes based on the most authoritative international standards.

The CHIARAVALLI GROUP SpA Technical Department is available however, to examine problems that relate to the choice, application and maintenance of couplings in collaboration with users.

On specific request, special couplings by their shape, execution and performance can be offered and produced, as an alternative to the normal execution couplings.

For example:

- Couplings designed for high angular and parallel misalignments.
- Couplings manufactured using high resistance steel and with surface hardening heat treatment.
- Couplings with case hardened and hardened hubs and using a hard metal tool).
- Special couplings manufactured to a drawing.

STRUCTURAL CHARACTERISTICS

The GFA range of compact couplings, comprise two toothed hubs and an external connecting single-piece sleeve.

The lubricant seal inside the coupling is ensured by two ring gaskets, arranged at the two ends of the sleeve and held in position by spring washers (Seeger washers).

Two threaded dowels arranged radially on the sleeve in a counter-position allow a solid lubricant to be adopted.

The toothing adopted for the two hubs is profile corrected and has a progressive dual curvature achieved by machine the toothing on a fully Numerically Controlled gear cutting machine.

The sleeve's profile corrected toothing, which has a parallel gene-ratrix, is obtained using a shaping tool.

The toothing is produced to category 7 precision, in compliance with DIN 3972 and has a degree of finish with a surface roughness of not more than Ra = 1.4 micrometres, thanks to the machining technology adopted.

Both the hubs and the sleeve are manufactured using hardened and tempered carbon steel with a tensile stress resistance of 800 N/mm. The couplings are subjected to a surface hardening thermo-chemical treatment at the end of the machining stage, which ensures a high resistance to wear and seizure and also confers a high resistance to corrosion caused by atmospheric agents.

The perfect seal achieved by the gaskets ensures the required lubricant containment and prevents penetration of contaminating elements from outside, thereby contributing to increase the average useful working life of the coupling, even if operating in an aggressive environment.

The two toothed hub bands are positioned at the maximum distance permitted by the sleeve length. This arrangement ensures a minimum angular misalignment for a given parallel misalignment and enhances the coupling's constant-velocity features.



The satisfactory operation and the useful working life of flexible toothed couplings depends on the correct selection of the couplings, as well as on the compatibility of the operating conditions with the performance provided by the coupling. It is essential therefore, to highlight the limiting performance of the couplings and to clarify the actions of the external loads that are exerted on the corresponding couplings.

The basic design ensures that all the couplings are capable of compensating a static angular or assembly misalignment equal to 1 degree and this is ensured by the minimum construction tolerance between the teeth.

The dynamic angular or operating misalignment must never be greater than 0.5 degrees, even if the recommended values should not be greater than 0.25 degrees.

The declared nominal torque values and the maximum rotating speeds indicated refer to an angular or composite misalignment that does not exceed 1/12 of a degree (5 prime divisions).

The 'exceptional' torque values that can be supported as a transient and during the acceleration phases must not be exerted for more than 10-15 seconds and must not occur for more than 5 events/hour.

Fatigue durations are calculated for a conventional limit of 50 million cycles, considering two load cycles for each revolution of the coupling.

Misalignments exceeding 1/8 degrees (7.5 prime divisions) penalise by decreasing the nominal torque and the maximum rotating speed declared for the individual couplings.

The performance of the coupling in terms of torque, limiting speed and useful working life will decrease or increase compared with the declared values in the case of operating conditions that differ from the conditions specified above or for "fixed-term" durations.

The design data has been tested for the purpose of ensuring a reasonable safety margin. The declared performance therefore, is to be understood as valid for a Service Factor equal to 1.

Use of the prescribed lubricants and compliance with the recommended restore time intervals represent the preconditions to achieve the performance as described

in the catalogue. The CHIARAVALLI GROUP SpA Technical Department is available to advise users in selecting the type of coupling most appropriate for the actual operating conditions and to make recommendations in relation to special operating conditions.

TECHNICAL DATA

COUPLING TYPE	Power Factor Kw		Torque Nm		Power transmitted in Kw at r.p.m.				r.p.m. max	r.p.m. recommended limit	max radial misalignment mm	mass kg	J kg cm ²
	normal	except.	normal	except.	750 normal	1000 normal	1500 normal	3000 normal					
GFA 25	0,061	0,157	600	1.524	45	61	91	183	6.000	5.000	0,20	1,36	8,68
GFA 32	0,103	0,259	1.000	2.520	77	103	154	309	5.000	4.000	0,26	2,51	25,10
GFA 40	0,128	0,322	1.250	3.125	96	128	192	384	4.200	3.000	0,32	3,55	44,82
GFA 56	0,257	0,639	2.500	6.200	192	257	385	-	3.500	2.200	0,37	6,15	132,60
GFA 63	0,412	0,985	4.000	9.260	309	412	618	-	3.000	1.600	0,40	9,91	278,20
GFA 80	0,773	1,855	7.500	18.000	579	773	-	-	2.600	1.200	0,48	16,20	558,6
GFA 100	1,236	2,937	12.000	28.500	927	-	-	-	1.400	700	0,65	23,00	1.044,50
GFA 125	2,431	5,795	23.600	56.250	1.823	-	-	-	950	460	0,70	49,15	3.650
GFA 155	4,121	9,273	40.000	90.000	3.090	-	-	-	700	350	0,80	91,30	9.982

N.B. Class G 2.5 dynamic balancing in compliance with ISO 1940 is recommended for actual operating speeds that exceed 3,600 r.p.m. Couplings can operate with a parallel misalignment value that is double the suggested value and assembly with a misalignment value that is four times greater than the suggested value in exceptional cases.

CAD drawings available on our site
www.chiaravalli.com

(1) Referred to the normal coupling complete with maximum bore without keyway.

**Quantity, availability and prices
on B2B Chiaravalli**



The torque, speed and useful working life data declared for the couplings are to be understood as valid referred to a Service Factor SF = 1.

The service factor must be determined therefore, based on the type of load, the load intensity and the range factor that characterises the type of load exerted on the coupling.

The values shown in the following table can be considered as a precautionary measure in the absence of reliable service factor design data.

LOAD CONDITION	OPERATING CONDITIONS	TYPE OF DRIVE	
		electric motor	diesel engine
UNIFORM	Regular operation without impacts or overloads	1,25	1,5
LIGHT	Regular operation with minor and infrequent impacts and overloads	1,50	2,0
MEDIUM	Irregular operation with medium overloads for a short duration and frequent but moderate impacts	2,0	2,5
HEAVY	Markedly irregular operation with very frequent impacts and overloads and of major intensity.	2,5	3,0

TEST BASED ON THE POWER TO BE TRANSMITTED

Use the following formula to calculate the value of the operating torque (Me) expressed in Nm, considering the drive motor power output (P) in kW and the operating speed (n) in r.p.m.

$$Me = \frac{9549 \times P}{n}$$

Establish the nominal torque to be transmitted (Mn) based on the service factor taken from the table.

$$Mn = Me \times FS$$

Select the coupling with a nominal torque which is GREATER than the value calculated.

WARNING

The declared nominal torques must be progressively decreased for angular misalignments that exceed 0.125 degrees.

TEST BASED ON THE SHAFT DIAMETER

Check that the largest of the shafts to be connected has a diameter equal to or less than the nominal bore declared for the coupling.

The maximum permitted diameter for the selected coupling should be limited to UNIFORM or LIGHT load conditions.

TEST BASED ON THE ROTATING SPEED

The maximum rotating speed indicated for each coupling represents an operating limit calculated for an angular misalignment that does not exceed 1/12 of a degree. Both the nominal torque and the permitted rotating speed are reduced for greater angular misalignments. Adopt a coefficient equal to 1.12 to increase the service factor and select the coupling as described previously when both the misalignment and the operating speed are less than the suggested reference values, but are close to these values. Contact our Technical Services for operating conditions with misalignments and operating speeds that exceed the suggested reference values.

TEST BASED ON THE REQUIRED USEFUL WORKING LIFE

Nominal operating conditions (torque, misalignment and rotating speed). Operating lifespans that exceed the standard duration cause the nominal torque to decrease.

The service factor must be multiplied by a lifespan coefficient defined as follows if a given operating lifespan, which exceeds the standard working lifespan, is required.

OPERATING LIFESPAN IN HOURS	3800	4000	6000	8000	12000	20000
LIFESPAN COEFFICIENT	1	1,06	1,17	1,26	1,39	1,58

The nominal torque verified for the lifespan must be further decreased in the fairly improbable circumstance in which the actual operating speed is greater than the maximum permitted operating speed for the misalignment conditions of the coupling when in operation.

COMPONENT PARTS OF THE "GIFLEX®" GFA COUPLING

COUPLING TYPE	POS. 1		POS. 2		POS. 3		POS. 4		POS. 5		Allen wrench	N° of pieces
	description	N° of pieces	description	N° of pieces	Seal ring Corteco NBR DIN 3760 A	N° of pieces	Flexible ring for bores DIN 472	N° of pieces	Flat dowel UNI 5923	N° of pieces		
GFA 25	sleeve	1	HUB	2	BA 42x56x7	2	56 I	2	M 6x8	2	D.3	1
GFA 32	sleeve	1	HUB	2	BA 56x72x8	2	72 I	2	M 6x8	2	D.3	1
GFA 40	sleeve	1	HUB	2	BA 64x80x8	2	80 I	2	M 6x8	2	D.3	1
GFA 56	sleeve	1	HUB	2	BA 80x100x10	2	100 I	2	M 6x8	2	D.3	1
GFA 63	sleeve	1	HUB	2	BA 100x125x12	2	125 I	2	M 6x8	2	D.3	1
GFA 80	sleeve	1	HUB	2	BA 125x160x12	2	160 I	2	M 6x8	2	D.3	1
GFA 100	sleeve	1	HUB	2	SMIM 150x180x12	2	180 I	2	M 6x8	2	D.3	1
GFA 125	sleeve	1	HUB	2	SM 190x220x15	2	220 I	2	M 6x8	2	D.3	1
GFA 155	sleeve	1	HUB	2	SMIM 240x280x15	2	280 I	2	M 6x8	2	D.3	1

COMPONENT PARTS OF THE "GIFLEX®" GFAS COUPLING

COUPLING TYPE	POS. 1		POS. 2		POS. 3		POS. 4		POS. 5		Allen wrench	N° of pieces
	description	N° of pieces	description	N° of pieces	Seal ring Serie UM Gaco NBR	N° of pieces	Flexible ring for bores DIN 471	N° of pieces	Flat dowel UNI 5923	N° of pieces		
GFAS 25	sleeve	1	HUB	1	UM 60x40x10	1	40 E	1	M 6x8	2	D.3	1
GFAS 32	sleeve	1	HUB	1	UM 75x55x10	1	55 E	1	M 6x8	2	D.3	1
GFAS 40	sleeve	1	HUB	1	UM 85x65x10	1	65 E	1	M 6x8	2	D.3	1
GFAS 56	sleeve	1	HUB	1	UM 100x80x10	1	80 E	1	M 6x8	2	D.3	1
GFAS 63	sleeve	1	HUB	1	UM 120x100x10	1	100 E	1	M 6x8	2	D.3	1
GFAS 80	sleeve	1	HUB	1	UM 155x125x15	1	125 E	1	M 6x8	2	D.3	1
GFAS 100	sleeve	1	HUB	1	UM 180x150x15	1	150 E	1	M 6x8	2	D.3	1



NORMAL HUB



LONG HUB



SLEEVE STEEL

GFA ASSEMBLY

- A)** Insert the stop ring (4) and the seal ring (2) on the shaft.
- B)** Assemble the hubs (2) on the relative shafts.
- C)** Sleeve (1) is to be fitted on the longest shaft.
- D)** Position the shafts close together and check that the distance G corresponds to the value indicated in the table.
- E)** Align the shafts and check the parallelism then tighten the hubs on the shaft.
- F)** Fill the tothing and the gap between the hubs with grease.
- G)** At this stage slide the sleeve (1) down and position the sealing rings (3) in its place and tighten the stop rings (4) in their seat.
- H)** Proceed as follows for disassembly: remove the stop rings (4) using a pair of pliers, separate the sleeve (1) from the hubs (2) and the GFA coupling is fully disassembled.

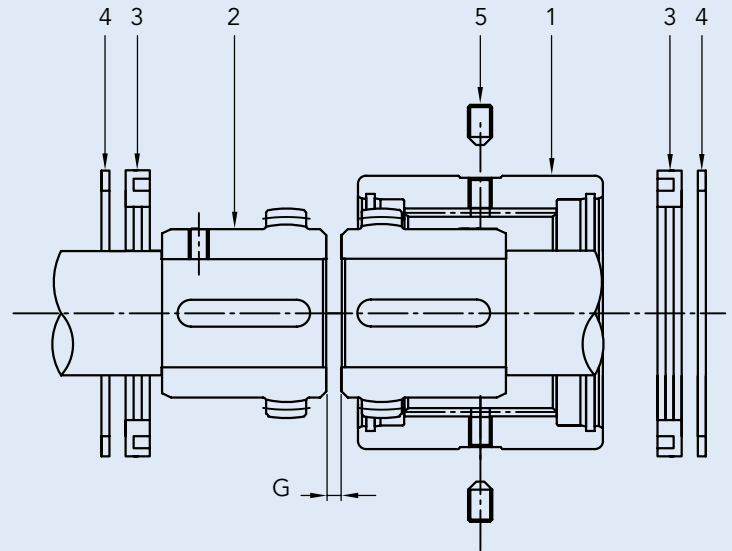
MAINTENANCE

Unscrew both plugs (5) then introduce grease using the grease gun through the greasing holes until the grease exits from the other hole positioned at 180°. Replace the plugs. Repeat this operation every 1.000 working hours.

Equivalent recommended greases are as follows:

TYPE	PRODUCER
Sovarex L-O	MOBIL OIL
Gulfrown EP-O	GULF OIL
Alesia EP-2	SHELL OIL
....

Couplings require lubrication with grease, the quantity of grease used should half fill the available gap.

Use of Lithium soap grease with a base mineral oil and consistency index 2 (in compliance with NLGI) is recommended for moderate loads and normal operating conditions.

Use Barium complex soap grease, PAO synthetic base oil and consistency index 2 for heavy-duty operating conditions as regards temperatures and with heavy loads.

Contact the CHIARAVALLI GROUP SpA Technical Department for extreme operating conditions.

The lubricant complying with the formulation and with the recommended characteristics can be selected from among the range of products indicated below by consulting the Producer.

N.B.

The technical characteristics, the dimensions and all other data contained in this catalogue are not binding.

CHIARAVALLI GROUP SpA reserves the right to change the measurements indicated at any time and without notice.



STEEL SLEEVE

INTERPRETATION CODES

EXAMPLE

GFA 25-NN with 2 normal hubs

GFA 25-NL with 1 normal hubs
and 1 long hub

GFA 25-LL with 2 long hubs

The characteristic size of the coupling is defined by the maximum diameter bore.

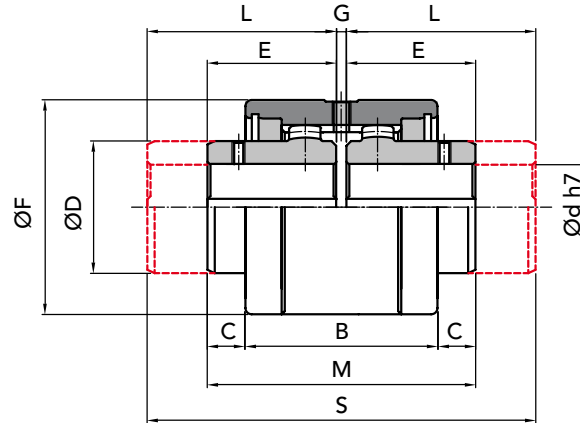

PART NUMBERS FOR COMPLETE COUPLING

PART NUMBERS FOR SIMPLE COMPONENTS

COUPLING TYPE	P. NUMBER GFA NN	P. NUMBER GFA NL	P. NUMBER GFA LL	SLEEVE	HUB NORMAL	HUB LONG	COMPONENTS to assembled coupling
GFA 25	00202502	00202500	00202504	00202510	00202520	00202540	00202560
GFA 32	00203202	00203200	00203204	00203210	00203220	00203240	00203260
GFA 40	00204002	00204000	00204004	00204010	00204020	00204040	00204060
GFA 56	00205602	00205600	00205604	00205610	00205620	00205640	00205660
GFA 63	00206302	00206300	00206304	00206310	00206320	00206340	00206360
GFA 80	00208002	00208000	00208004	00208010	00208020	00208040	00208060
GFA 100	00210002	00210000	00210004	00210010	00210020	00210040	00210060
GFA 125	00212502	00212500	00212504	00212510	00212520	00212540	00212560
GFA 155	00215502	00215502	00215504	00215510	00215520	00215540	00215560

MEASUREMENTS - WEIGHTS

COUPLING TYPE	Ø bore nom.	Ød available holes with H7 tolerance		measures in mm									Kg		
		ON REQUEST		normal series						long series			sleeve	HUB normal	HUB long
		min	max	B	C	ØD	E	ØF	G	M	L	S			
GFA 25	-	25	28	61	12	42	41	68	3	85	60	123	0,72	0,48	0,69
GFA 32	-	32	38	73	13,5	55	48,5	85	3	100	80	163	1,14	0,99	1,58
GFA 40	-	40	48	82	16,5	64	56	95	3	115	80	163	1,68	1,49	2,10
GFA 56	-	56	60	97	21,5	80	68	120	4	140	100	204	2,86	2,96	4,22
GFA 63	-	63	70	108	22,5	100	74,5	140	4	153	119,5	243	3,75	4,90	7,67
GFA 80	-	80	90	125	22,5	125	82,5	175	5	170	140	285	5,58	8,72	14,26
GFA 100	-	100	110	148	34	150	105	198	6	216	174,5	355	6,63	15,76	25,40
GFA 125*	40	125	140	214	39	190	140	245	8	288	207,5	423	17,70	32,60	49,50
GFA 155*	40	155	175	240	64	240	180	300	10	370	245	498	28,30	65,50	91,40

* Row material quenched steel 39NiCrMo3



On request: we execute machining for finish bore and keyway.

IMPORTANT

The GFA couplings can be ordered complete or for single items.

CAD drawings available on our site
www.chiaravalli.com

Quantity, availability and prices
on B2B Chiaravalli

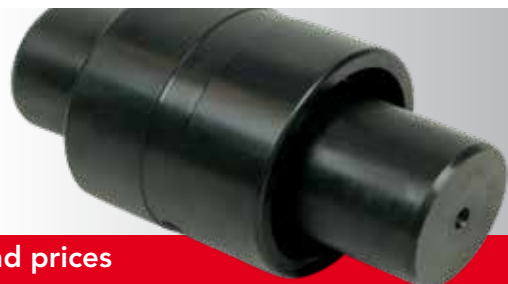

FLEXIBLE TOOTHED COUPLINGS WITH DUAL CURVATURE "GIFLEX" SERIES GFA with STEEL SLEEVE